

**Pioneer** *sound.vision.soul*

DVD/CD RECEIVER

**XV-DV505**

SPEAKER SYSTEM

**S-DV505**

Operating Instructions

**DVD**  
VIDEO

COMPACT  
**disc**  
DIGITAL AUDIO

COMPACT  
**disc**  
DIGITAL VIDEO

## CONGRATULATIONS ON YOUR PURCHASE OF THIS FINE PIONEER PRODUCT.

Pioneer is on the leading edge of DVD research for consumer products and this unit incorporates the latest technological developments.

We are sure you will be fully satisfied with the DVD player.

Thank you for your support.

Location: underside of the unit

## IMPORTANT



The lightning flash with arrowhead symbol, within an equilateral triangle, is intended to alert the user to the presence of uninsulated "dangerous voltage" within the product's enclosure that may be of sufficient magnitude to constitute a risk of electric shock to persons.



**CAUTION:** TO PREVENT THE RISK OF ELECTRIC SHOCK, DO NOT REMOVE COVER (OR BACK). NO USER-SERVICEABLE PARTS INSIDE. REFER SERVICING TO QUALIFIED SERVICE PERSONNEL.



The exclamation point within an equilateral triangle is intended to alert the user to the presence of important operating and maintenance (servicing) instructions in the literature accompanying the appliance.

H002\_En

**WARNING:** THIS APPARATUS IS NOT WATERPROOF. TO PREVENT FIRE OR SHOCK HAZARD, DO NOT EXPOSE THIS APPARATUS TO RAIN OR MOISTURE AND DO NOT PUT ANY WATER SOURCE NEAR THIS APPARATUS, SUCH AS VASES, FLOWER POTS, COSMETICS CONTAINERS, MEDICINE BOTTLES, ETC.

**WARNING:** BEFORE PLUGGING IN THE UNIT FOR THE FIRST TIME, READ THE FOLLOWING SECTION CAREFULLY. THE VOLTAGE OF THE AVAILABLE POWER SUPPLY DIFFERS ACCORDING TO COUNTRY OR REGION. BE SURE THAT THE POWER SUPPLY VOLTAGE OF THE AREA WHERE THIS UNIT WILL BE USED MEETS THE REQUIRED VOLTAGE (E.G., 230V OR 120V) WRITTEN ON THE REAR PANEL.

H041A\_En

European model only:

*This product complies with the Low Voltage Directive (73/23/EEC, amended by 93/68/EEC), EMC Directives (89/336/EEC, amended by 92/31/EEC and 93/68/EEC).*

H015AEn

## CAUTION

This product contains a laser diode of higher class than 1. To ensure continued safety, do not remove any covers or attempt to gain access to the inside of the product. Refer all servicing to qualified personnel.

The following caution label appears on your unit.

Location: underside of the unit



H018A\_En

**WARNING:** NO NAKED FLAME SOURCES, SUCH AS LIGHTED CANDLE, SHOULD BE PLACED ON THE APPARATUS. IF NAKED FLAME SOURCES ACCIDENTALLY FALL DOWN, FIRE SPREAD OVER THE APPARATUS THEN MAY CAUSE FIRE.

H044\_En

Replacement and mounting of an AC plug on the power supply cord of this unit should be performed only by qualified service personnel.

## IMPORTANT

### FOR USE IN THE UNITED KINGDOM

The wires in this mains lead are coloured in accordance with the following code:

Blue : Neutral  
Brown : Live

If the plug provided is unsuitable for your socket outlets, the plug must be cut off and a suitable plug fitted.

The cut-off plug should be disposed of and must not be inserted into any 13 amp socket as this can result in electric shock. The plug or adaptor or the distribution panel should be provided with 5 A fuse. As the colours of the wires in the mains lead of this appliance may not correspond with coloured markings identifying the terminals in your plug, proceed as follows:  
The wire which is coloured blue must be connected to the terminal which is marked with the letter N or coloured black.  
The wire which is coloured brown must be connected to the terminal which is marked with the letter L or coloured red.

Do not connect either wire to the earth terminal of a three pin plug.

**NOTE**  
After replacing or changing a fuse, the fuse cover in the plug must be replaced with a fuse cover which corresponds to the colour of the insert in the base of the plug or the word that is embossed on the base of the plug, and the appliance must not be used without a fuse cover. If lost replacement fuse covers can be obtained from your dealer.  
Only 5 A fuses approved by B.S.I. or A.S.T.A to B.S. 1362 should be used.

H005BEn

## VENTILATION:

### *European and Australian models:*

When installing this unit, make sure to leave space around the unit for ventilation to improve heat radiation (at least 10 cm at top, 10 cm at rear, and 10 cm at each side).

### *All other models:*

When installing this unit, make sure to leave space around the unit for ventilation to improve heat radiation (at least 20 cm at top, 15 cm at rear, and 15 cm at each side).

**WARNING:** Slot and openings in the cabinet are provided for ventilation and to ensure reliable operation of the product and to protect it from overheating, to prevent fire hazard, the openings should never be blocked and covered with items, such as newspapers, table-cloths, curtains, etc. Also do not put the apparatus on the thick carpet, bed, sofa, or fabric having a thick pile.

H040 En

## Wall mounting the speakers

### Before mounting

- Remember that this speaker system is heavy and that its weight may cause the wood screw to work loose or the wall to fail to support it, in which case the speaker system may fall on the floor. This is extremely dangerous. Make absolutely sure that the wall is sturdy enough to support the weight of the speaker system. Do not mount it on plywood boards or soft-surface walls. The mounting screws are not included with this unit. Please find the correct screws for your application.

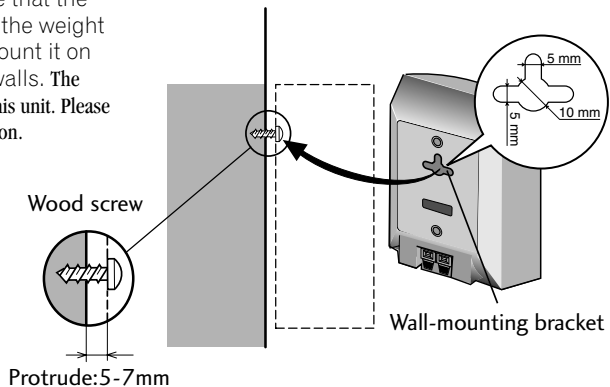

### Note

- If you are unsure of the quality and/or strength of the wall, consult a professional for advice.
- Pioneer is not responsible for any accidents or damage that result from improper installation.

## Energy-saving design

This system is designed to use 0.5 W of electricity when power is switched to Standby.

**CAUTION:** THE STANDBY/ON BUTTON IS SECONDARY CONNECTED AND THEREFORE DOES NOT SEPARATE THE UNIT FROM MAINS POWER IN STANDBY POSITION. therefore install the unit suitable places easy to disconnect the MAINS plug in case of the accident. The MAINS plug of unit should be unplugged from the wall socket when left unused for a long period of time.

H017B\_En

## Operating Environment H045\_En

Operating environment temperature and humidity:

+5°C – +35°C (+41°F – +95°F); less than 85%RH (cooling vents not blocked)

Do not install in the following locations

- Location exposed to direct sunlight or strong artificial light
- Location exposed to high humidity, or poorly ventilated location

**CAUTION:** These speaker terminals can be under HAZARDOUS VOLTAGE. When you connect or disconnect the speaker cables, to prevent the risk of electric shock, do not touch uninsulated parts before disconnecting the power cord. H047 En

# Contents

## 01 Before you start

Introduction to home theater .....	6
General disc compatibility .....	6
CD-R/RW compatibility .....	6
DVD-R/RW compatibility .....	7
PC-created disc compatibility .....	7
MP3 audio compatibility .....	7
Titles, chapters and tracks .....	8
DVD Video regions .....	8

## 02 Controls and displays

Front panel .....	9
Remote control .....	10
Display .....	12

## 03 Getting started

Setting the unit to match your TV system .....	14
Using the Quick Room Setup .....	15
Setting the clock .....	15
Changing the clock format .....	16
Setting up the remote to control your TV .....	16
Using the on-screen displays .....	17
Playing discs .....	17
Basic playback controls .....	19
Front panel controls .....	20
DVD-Video disc menus .....	20
Video CD PBC menus .....	21
Listening to auxiliary components .....	21
Automatic power on buttons .....	21

## 04 Playing discs

Introduction .....	22
Using the Disc Navigator to browse the contents of a disc .....	22
Scanning discs .....	23
Playing in slow motion .....	23
Frame advance/frame reverse .....	24
Looping a section of a disc .....	24
Using repeat play .....	25
Using the OSD .....	25
Using the front panel display .....	26
Using random play .....	26

Using the OSD .....	26
Using the front panel display .....	27
Creating program lists .....	28
Using the OSD .....	28
Editing program lists using the OSD .....	29
Other functions available from the OSD program menu .....	30
Using the front panel display .....	30
Clearing a track from the program list .....	31
Clearing the program list .....	31
Searching a disc .....	31
Switching subtitles .....	32
Switching DVD audio languages .....	32
Switching audio channels when playing a Video CD .....	32
Zooming the screen .....	32
Switching camera angles .....	33
Displaying disc information .....	33
Using the OSD .....	33
Using the front panel display .....	34

## 05 Listening to the radio

Choosing stations .....	35
Improving poor FM reception .....	35
Memorizing stations .....	36
Listening to station presets .....	36
An introduction to RDS .....	37
Using the RDS display .....	38
Searching for RDS programs .....	38

## 06 Setting up for surround sound

Choosing your surround sound settings .....	39
Front speaker distance setting .....	40
Center speaker distance setting .....	40
Surround speaker distance setting .....	40
Dynamic range control setting .....	40
Dual mono setting .....	41
LFE attenuator setting .....	41
Setting the relative volume level of each channel .....	41

## 07 Playing sources

Using the multi-channel sound modes .....	43
Auto .....	43
Surround modes .....	43
Advanced Surround modes .....	43
Stereo .....	44
Listening to multi-channel playback .....	44
Listening to a stereo source .....	45
Using Advanced Surround .....	46
Using the headphones with Advanced Surround .....	46

## 08 Adjusting the sound

Adjusting the bass and treble .....	47
Adjusting the effect level .....	47
Boosting the bass level .....	47
Using Midnight and Quiet listening .....	48
Muting the sound .....	48
Reducing the TV and line signal levels .....	48

## 09 Using the timer

Setting the wake-up timer .....	49
Turning the wake-up timer on/off .....	50
Setting the sleep timer .....	50

## 10 The Initial Settings menu

Using the Initial Settings menu .....	51
Video settings .....	51
TV Screen .....	51
S Video Out .....	52
Language settings .....	52
Audio Language .....	52
Subtitle Language .....	52
DVD Menu Language .....	53
Subtitle Display .....	53
Display settings .....	53
OSD Language .....	53
On Screen Display .....	53
Angle Indicator .....	54
Options .....	54
Parental Lock .....	54

Registering a new password .....	54
Changing your password .....	55
Setting/changing the Parental Lock level .....	55
Setting/changing the Country Code .....	56

## 11 Additional information

Switching off the demo .....	57
Dimming the display .....	57
Changing the frequency step .....	57
Setting the TV format .....	57
Resetting the unit .....	57
Child Lock .....	58
Using discs with this unit .....	59
Handling discs .....	59
Storing discs .....	59
Discs to avoid .....	59
Proper installation and maintenance of this unit .....	60
Hints on installation .....	60
Cleaning the pickup lens .....	60
Problems with condensation .....	60
Moving the unit .....	60
Additional connections .....	61
Connecting external antennas .....	61
Connecting auxiliary components .....	61
Troubleshooting .....	63
General .....	63
DVD/CD/Video CD player .....	64
Tuner .....	65
Error Messages .....	65
Screen sizes and disc formats .....	66
Widescreen TV users .....	66
Standard TV users .....	66
Language code list .....	67
Country code list .....	67
Preset Code List .....	68
Glossary .....	70
Specifications .....	72
Power cord caution .....	73

## Introduction to home theater

You are probably used to using stereo equipment to listen to music, but may not be used to home theater systems that give you many more options (such as surround sound) when listening to soundtracks.

Home theater refers to the use of multiple audio channels to create a surround sound effect, making you feel like you're in the middle of the action or concert. The surround sound you get from a home theater system depends not only on the speakers you have set up in your room, but also on the source and the sound settings of the system.

DVD-Video has become the basic source material for home theater due to its size, quality, and ease of use. Depending on the DVD, you can have up to seven different audio tracks coming from one disc, all of them being sent to different speakers in your system. This is what creates a surround sound effect and gives you the feeling of 'being there'.

This receiver will automatically decode Dolby Digital, DTS or Dolby Surround DVD-Video discs. In most cases, you won't have to make changes for realistic surround sound, but other possibilities (like listening to a CD with multi-channel surround sound) are explained in *Playing sources*, starting on page 43.

## General disc compatibility

This player was designed and engineered to be compatible with software bearing one or more of the following logos.



Other formats, including but not limited to the following, are not playable in this player:

- **DVD-Audio, SACD, Photo CD, DVD-RAM, DVD-ROM, CD-ROM\***  
(\*except those that contain MP3 files formatted as specified in the *MP3 audio compatibility* section)



### Note

- DVD-R/RW and CD-R/RW discs (Audio CDs and Video CDs) recorded using a DVD recorder, CD recorder or personal computer may not be playable on this machine. This may be caused by a number of possibilities, including but not limited to: the type of disc used; the type of recording; damage, dirt or condensation on either the disc or the player's pick-up lens.

## CD-R/RW compatibility

- This unit will play CD-R and CD-RW discs recorded in CD Audio or Video CD format, or as a CD-ROM containing MP3 audio files. However, any other content may cause the disc not to play, or create noise/distortion in the output.

- This unit cannot record CD-R or CD-RW discs.
- Unfinalized CD-R/RW discs recorded as CD Audio can be played, but the full Table of Contents (playing time, etc.) will not be displayed.

### DVD-R/RW compatibility

- This unit will play DVD-R/RW discs that were recorded using the DVD Video format.
- This unit will not play DVD-RW discs that were recorded using the Video Recording format.
- This unit cannot record DVD-R/RW discs.
- Unfinalized DVD-R/RW discs cannot be played in this player.

### PC-created disc compatibility

- If you record a disc using a personal computer, even if it is recorded in a compatible format as listed above, there will be cases in which the disc may not be playable in this machine due to the setting of the application software used to create the disc. In these particular instances, check with the software publisher for more detailed information.
- Check the DVD-R/RW or CD-R/RW software disc boxes for additional compatibility information.

### MP3 audio compatibility

- This unit will play CD-ROM discs containing files saved in the MPEG-1 Audio Layer 3 format (MP3) with a sampling rate of 32, 44.1 or 48kHz. Incompatible files will not play and **UNPLAYABLE** will show in the display.
- Fixed bit-rate files are recommended. Variable bit-rate (VBR) files are playable, but playing time may not be shown correctly.
- The CD-ROM used to compile your MP3 files must be ISO 9660 Level 2 compliant.
- CD physical format: Mode1, Mode2 XA Form1.
- This player only plays tracks that are named with the file extension “.mp3” or “.MP3”.
- This player is not compatible with multi-session discs. If you try and play a multi-session disc, only the first session will be played.
- Use CD-R or CD-RW media for recording your MP3 files. The disc must be finalized in order to play in this unit.
- This player can recognize a maximum of 250 folders and 250 tracks. Discs containing more than 250 folders or 250 tracks will play, but only the first 250 folders / tracks.
- Folder and track names (excluding the “.mp3” extension) are displayed.

- There are many different recording bit-rates available to encode your MP3 files. This unit was designed to be compatible with all of them. Audio encoded at 128Kbps should sound close to regular CD Audio quality. This player will play lower bit-rate MP3 tracks, but please note that the sound quality becomes noticeably worse at lower bit-rates.

### Titles, chapters and tracks

DVD discs are generally divided into one or more titles. Titles may be further subdivided into chapters.

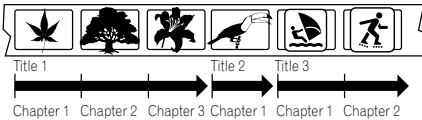

CDs and Video CDs are divided into tracks.

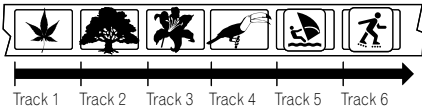

CD-ROMs containing MP3 files are divided into folders and tracks. Folders may also contain further subfolders.

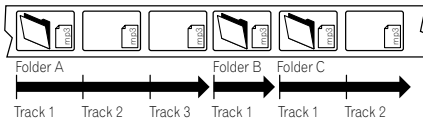

### DVD Video regions

All DVD Video discs carry a region mark on the case somewhere that indicates which region(s) of the world the disc is compatible with. Your DVD player also has a region mark, which you can find on the rear panel. Discs from incompatible regions will not play in this player. Discs marked **ALL** will play in any player.

The diagram below shows the various DVD regions of the world.

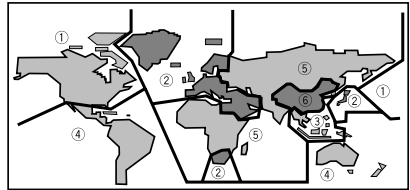



## Front panel

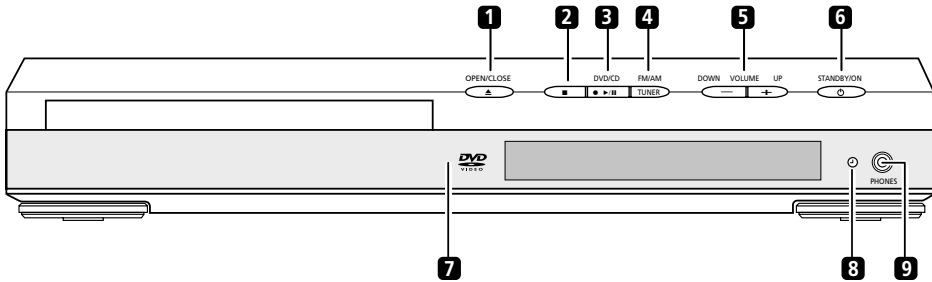

### 1 OPEN/CLOSE

Opens the disc tray

### 2 ■

Stops playback

### 3 DVD/CD / ►||

Switches to the DVD/CD function and starts/pauses/resumes playback

### 4 FM/AM (TUNER)

Switches to the tuner function and toggles between the AM and FM bands

### 5 VOLUME buttons

Adjusts the volume

### 6 ⏻ STANDBY/ON

Switches the player on or into standby

### 7 Remote sensor

### 8 Timer indicator

Lights when the timer is set

### 9 PHONES jack

Headphone jack

## Remote control

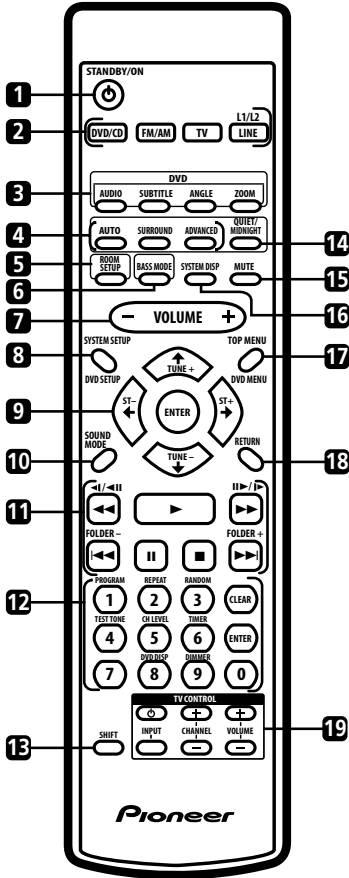

- 1** **⏻ STANDBY/ON**  
Switches the player on or into standby
- 2** **Function select buttons**  
Selects the source you want to listen to

### 3 DVD buttons

#### AUDIO

Selects the audio channel or language (page 32)

#### SUBTITLE

Selects a subtitle display (page 32)

#### ANGLE

Changes the camera angle during DVD multi-angle scene playback (page 33)

#### ZOOM

Changes the zoom level (page 32)

### 4 Sound mode buttons

#### AUTO

Automatically selects a decoding format depending on the source (pages 43–45)

#### SURROUND

Selects a surround mode (pages 43–45)

#### ADV. SURROUND

Selects a DSP mode (pages 43–44, 46)

### 5 ROOM SETUP

Press to automatically adjust the surround sound settings according to your room type (**S**, **M**, or **L**) (page 15)

### 6 BASS MODE

Press to bring up the low end for certain kinds of music or sound sources (page 47)

### 7 VOLUME

Adjusts the volume

### 8 DVD SETUP

Displays (or exits) the on-screen DVD display

## SYSTEM SETUP (SHIFT+DVD SETUP)

Press to make various system settings in standby; choose your surround sound settings when the unit is switched on

## 9 ENTER, TUNE & cursor control buttons

Navigates on-screen displays and menus;

**ENTER** selects an option or executes a command

## 10 SOUND MODE

Adjusts the tone and effect level (page 47)

## 11 Playback controls



Starts/resumes playback

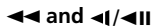

Use for reverse slow motion playback, frame reverse and reverse scanning



Use for forward slow motion playback, frame advance and forward scanning



Jumps to the beginning of the current chapter/track (or folder by pressing **SHIFT** + ) , then to previous chapters/tracks/folders



Jumps to the next chapter/track (or folder by pressing **SHIFT** + )



Pauses playback; press again to restart



Stops playback

## 12 Number buttons and SHIFT functions

The number buttons can be used for selecting tracks directly, the functions above the buttons are accessed by pressing **SHIFT** at the same time as the button.

### PROGRAM

Use to program/play a program list (pages 30–31)

### REPEAT

Selects a repeat play mode (page 26)

### RANDOM

Selects a random play mode (page 27)

### TEST TONE

Outputs the test tone (for speaker setup) (pages 41–42)

### CH LEVEL

Press to adjust the speaker level (page 42)

### TIMER

Selects the timer menu (pages 49–50, 15)

### DVD DISP

Changes the displayed information on the display (pages 33–34)

### DIMMER

Makes the fluorescent display (FL) dimmer or brighter (page 57)

### CLEAR

Clears an entry

### ENTER

Selects menu options, etc. (works exactly the same as the **ENTER** button in 9 above)

## 13 SHIFT

Press to access the functions/commands written in green on the remote

**14 QUIET/MIDNIGHT**

Adjusts the sound for low listening levels (page 48)

**15 MUTE**

Mutes the volume

**16 SYSTEM DISP**

Switches between information and clock displays

**17 DVD MENU**

Displays the DVD menu (for CDs, Video CDs and MP3 discs, the Disc Navigator screen appears)

**TOP MENU (SHIFT + DVD MENU)**

Displays the top menu of a DVD disc

**18 RETURN**

Press to return to a previous menu screen

**19 TV CONTROL**

Switches the TV on or into standby

**INPUT SELECT**

Switches the TV input

**CHANNEL +/-**

Selects channels on the TV

**VOLUME +/-**

Adjusts the volume on the TV

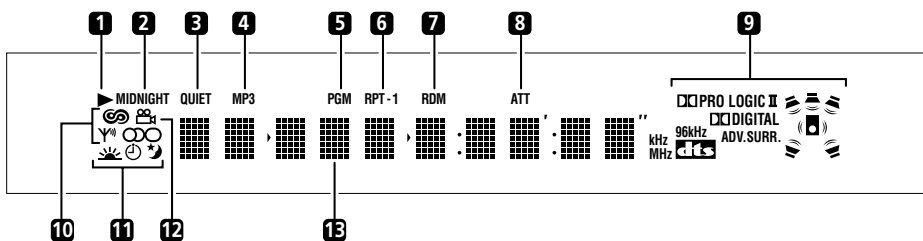
**Display****1** ▶

Lights during playback of a CD, VCD, DVD or MP3

**2 MIDNIGHT**

Lights during Midnight listening

**3 QUIET**

Lights when the Quiet mode is switched on

**4 MP3**

Lights during playback of an MP3 disc

## 5 PGM

Lights during program play

## 6 RPT-1

**RPT** lights during repeat play (**RPT-1** lights during repeat one-track play)

## 7 RDM

Lights during random playback

## 8 ATT

Lights when you attenuate (reduce) the line signal level (can only be used with an analog signal)

## 9 Surround sound indicators

### **PRO LOGIC II**

This lights to indicate Dolby Prologic II decoding

### **DIGITAL**

This lights to indicate decoding of a Dolby Digital\*1 signal

### **96kHz**

Lights when a 96kHz source is detected (won't light if the source is copy-protected)

### **ADV. SURR**

Lights when one of the Advanced Surround listening modes is selected

### **DTS**

This lights to indicate decoding of a DTS\*2 signal

### **Speaker indicators (🔊)**

These indicate either stereo (🔊🔊) or multi-channel (all speakers light in the display) listening



### Note

Even when all indicators are lit, you may not hear sound from all the speakers in your setup.

## 10 Tuner indicators



*European model only*

Lights when in one of the RDS display or search modes



Lights when a broadcast is being received



Lights when a stereo FM broadcast is being received in auto stereo mode



Lights when FM mono reception is selected

## 11 Timer indicators



Lights when the wake-up timer is active



Lights when the timer is set



Lights when the sleep timer is active

## 12

Lights during multi-angle scenes on a DVD disc

## 13 Character display

\*1 *Manufactured under license from Dolby Laboratories. "Dolby", "Pro Logic" and the double-D symbol are trademarks of Dolby Laboratories.*

\*2 *"DTS" and "DTS Digital Surround" are registered trademarks of Digital Theater Systems, Inc.*

## Setting the unit to match your TV system

When you switch on the system for the first time, you should see a welcome screen displayed on your TV. From here you can set up the player to work with the kind of TV you have. After this, use the Quick Room Setup (next page) to jump right in and start playing some discs.

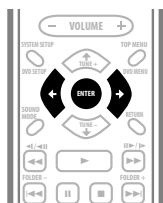

**1 European model only:** Use the **↑/↓** buttons (cursor up/down) to choose a language.

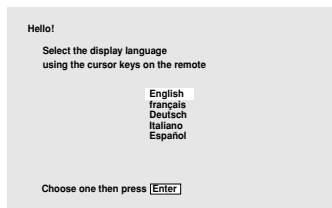

**2 Press ENTER to move on to the next screen.**

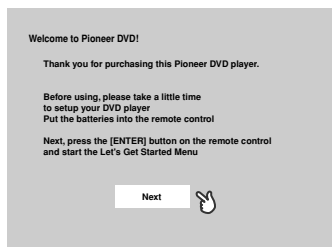

**3 Use the **←/→** (cursor left/right) buttons to select either 'Wide screen' or 'Standard size screen' according to the kind of TV you have, then press ENTER.**

See also *Screen sizes and disc formats* on page 66 if you're not sure which one to choose.

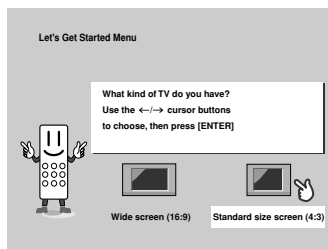

**4 Press ENTER again to finish setting up.**

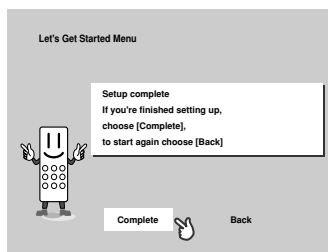

- Select **BACK** then press **ENTER** if you want to go back and change the setting you just made.

## Using the Quick Room Setup

- Default setting: **M** (U.S. model only — see note below)

Depending on the distance of your speakers from the listening position, choose between **Small**, **Medium**, or **Large** (see the following table).

- Press **ROOM SETUP** repeatedly to select your room type then press **ENTER**.

	<b>S</b>	<b>M</b>	<b>L</b>
<b>Front</b>	1.8m (6 ft)	1.8m (6 ft)	1.8m (6 ft)
<b>Center</b>	1.5m (5 ft)	1.5m (5 ft)	1.5m (5 ft)
<b>Surround</b>	0.9m (3 ft)	1.8m (6 ft)	2.7m (9 ft)



### Note

- The channel levels will also be adjusted according to the distance setting.
- If you have already set the channel levels manually (see *Setting the relative volume level of each channel* on page 41), you will see **ROOM --** in the display when you first press the **ROOM SETUP** button.

*Except for U.S. model*

- Since the default channel levels are not the same as the channel levels for any of the room setup options, **ROOM --** will show in the display when you first press the **ROOM SETUP** button. See *Setting the relative volume level of each channel* on page 41 for more on individual channel level settings.

## Setting the clock

After setting the unit to match your TV system, the first thing to do is to set the clock. This only needs to be done once (unless all power to the unit is cut) and will enable you to use the timer features.

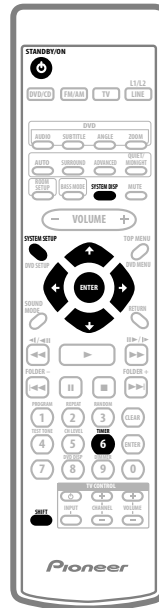

- 1 Press **TIMER (SHIFT+6)**.
- 2 If **CLOCK ADJ** isn't already selected, use the **←/→** buttons to select it.
- 3 Press **ENTER**.
- 4 Use the **↑/↓** buttons to set the hour.
- 5 Press **ENTER**.

**6 Use the  $\uparrow/\downarrow$  buttons to set the minute.**

**7 Press ENTER to confirm.**

The display flashes to indicate the clock is set.



#### Tip

- Press **SYSTEM DISP** anytime to cycle through display options to show the current time. See *Displaying disc information* on pages 33–34 for more on this.

## Changing the clock format

- Default setting: **12-HOUR**

You can choose to display the clock in either 12 or 24 hour formats.

**1 Switch the system into standby.**

**2 Press SYSTEM SETUP (SHIFT+DVD SETUP).**

**3 Use the  $\leftarrow/\rightarrow$  buttons to select hour format (Default setting: 12-HOUR).**

The current clock format is shown in the display.

**4 Use the  $\uparrow/\downarrow$  buttons to select either 12 or 24 hour clock format.**

**5 Press ENTER to confirm.**

## Setting up the remote to control your TV

You can set up the supplied remote to control your TV. Here's how to set it up.

**1 Switch on your TV.**

**2 Find the name of the manufacturer of your TV in the Preset Code List on page 68-69.**

Next to each manufacturer is one or more three digit codes. These tell the remote what kind of TV you have.

If the name of the manufacturer of your TV does not appear in the table, you won't be able to set up this remote to control your TV.

**3 Point the remote at your TV, hold down the CLEAR button, then enter the three digit code for your TV.**

The remote transmits an on/off signal to the TV. If you've entered the correct code, your TV should switch off.

If your TV doesn't turn off, repeat the procedure using the next code in the list until your TV switches off successfully. Once set, you can then use the following individual TV controls.

Button	What it does
	Switches your TV on or into standby.
<b>CHANNEL +/-</b>	Changes the TV channel.
<b>VOLUME +/-</b>	Adjusts the volume.
<b>INPUT</b>	Switches the TV's input between the built in TV tuner and an external video source.



## Using the on-screen displays

For ease of use, this player makes extensive use of graphical on-screen displays (OSDs). You should get used to the way these work as you'll need to use them when setting up the player, using some of the playback features, such as program play, and when making more advanced settings for audio and video.

All the screens are navigated in basically the same way, using the cursor buttons to change the highlighted item and pressing **ENTER** to select it.



Button	What it does
<b>DVD SETUP</b>	Displays/exits the on-screen display
← → ↶ ↷	Changes the highlighted menu item
<b>ENTER</b>	Selects the highlighted menu item (both <b>ENTER</b> buttons work in exactly the same way)
<b>RETURN</b>	Returns to the main menu without saving changes



### Important

- Throughout this manual, 'Select' means use the cursor buttons to highlight an item on-screen, then press **ENTER**.



### Tip

- The button guide at the bottom of every OSD screen shows you which buttons you'll need to use for that screen.

## Playing discs

The basic playback controls for playing DVD, CD, Video CD and MP3 discs are covered here. Further functions are detailed in the **next chapter**.

### 1 If the player isn't already on, press **⏻** **STANDBY/ON** to switch it on.

If you're playing a DVD or Video CD, also turn on your TV and make sure that it is set to the correct video input.

### 2 Press **⏏** **OPEN/CLOSE** to open the disc tray.

### 3 Load a disc.

Load a disc with the label side facing up, using the disc tray guide to align the disc (if you're loading a double-sided DVD disc, load it with the side you want to play face down).

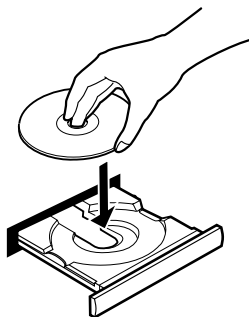

#### 4 Press ► (►/II) to start playback.

If you're playing a DVD or Video CD, a menu may appear. See pages 20–21 for how to navigate these.

If you're playing an MP3 disc, it may take a few seconds before playback starts, depending on the complexity of the file structure on the disc.



#### FAQ

- *After I load a DVD disc, it ejects automatically after a few seconds!*

Most likely, the disc is the wrong region for your player. The region number should be printed on the disc; check it against the region number of the player (which you can find on the rear panel). See also page 8.

If the region number is OK, it may be that the disc is damaged or dirty. Clean the disc and look for signs of damage. See also page 59.

- *Why won't the disc I loaded play?*

First check that you loaded the disc the right way up (label side up), and that it's clean and not damaged. See page 59 for information on cleaning discs.

If a disc loaded correctly won't play, it's probably an incompatible format or disc type, such as DVD-Audio or DVD-ROM. See page 6 for more on disc compatibility.

- *I have a widescreen TV so why are there black bars at the top and bottom of the screen when I play some discs?*

Some movie formats are such that even when played on a widescreen TV, black bars are necessary at the top and bottom of the screen. This is not a malfunction.

- *I have a standard (4:3) TV and set the player to show widescreen DVDs in pan & scan format, so why do I still get black bars top and bottom with some discs?*

Some discs override the display preferences of the player, so even if you have **4:3 (Pan & Scan)** selected, those discs will still be shown in letterbox format. This is not a malfunction.

## Basic playback controls

The table below shows the basic controls on the remote for playing discs. The following chapter covers more playback features in more detail.

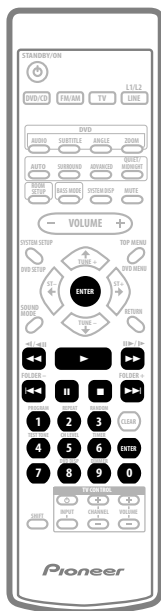

Button	What it does
▶	Starts playback. DVD and Video CD: if the display shows <b>RESUME</b> , playback starts from the resume point.
	Pauses a disc that's playing, or restarts a paused disc.
■	Stops playback. DVD and Video CD: Display shows <b>RESUME</b> . Press ■ again to cancel the resume function.
◀◀	Press to start fast reverse scanning. Press ▶ (play) to resume normal playback.
▶▶	Press to start fast forward scanning. Press ▶ (play) to resume normal playback.
◀◀	Skips to the start of the current track or chapter, then to previous tracks/chapters.
▶▶	Skips to the next track or chapter.
<b>FOLDER +/-</b> <b>(SHIFT+)</b> ◀◀/▶▶	Skips to the next/previous folder when listening to an MP3 disc.
<b>Numbers</b>	<ul style="list-style-type: none"> <li>If the disc is stopped, playback starts from the selected title (for DVD) or track number (for CD/Video CD) after a few seconds (or after pressing <b>ENTER</b>).</li> <li>If the disc is playing, playback jumps to the start of the selected chapter or track after a few seconds (or after pressing <b>ENTER</b>).</li> </ul>



## Video CD PBC menus

Some Video CDs have menus from which you can choose what you want to watch. These are called PBC (Playback control) menus.

You can play a PBC Video CD without having to navigate the PBC menu by starting playback using a number button to select a track, rather than the ► (►/II) button.



Button	What it does
RETURN	Displays the PBC menu.
Numbers	Selects a numbered menu option.
◀◀	Displays the previous menu page (if there is one).
▶▶	Displays the next menu page (if there is one).

## Listening to auxiliary components

After you have connected a source to the **LINE** jack(s) on the rear of the unit, you can listen to the auxiliary component(s) by pressing the **LINE** button.

If you have chosen to connect your TV (or a component other than the TV) to the **TV** (AUDIO) jacks on the rear panel, press the **TV** button to hear it.

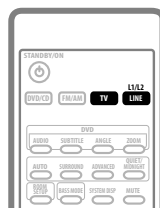

- Press the **LINE** button repeatedly to switch between **LINE 1** (analog) and **LINE 2** (digital).
- Press the **TV** button to hear the **TV** through this system.

## Automatic power on buttons

There are a number of buttons other than **STANDBY/ON** (power symbol) which will switch the unit on. **OPEN/CLOSE** (front panel only), **DVD/CD** (►/II on the front panel), **FM/AM**, **TV**, and **LINE** switch the unit on directly into that function. (In the case of **DVD/CD** (►/II), if there is a DVD or a CD loaded it will start playing.)

## Introduction

With most of the features described in this chapter, you can make use of on-screen displays. For an explanation of how to navigate these, see *Using the on-screen displays* on page 17.

Many of the functions covered in this chapter apply to DVD discs, Video CDs, CDs and MP3s, although the exact operation of some varies slightly with the kind of disc loaded. With CDs and MP3 discs, you can use the front panel display instead of the OSD for many features.

Some DVD discs restrict the use of some functions (random or repeat, for example). This is not a malfunction.

When playing Video CDs, some of the functions are not available during PBC playback. If you want to use them, start the disc playing using a number button to select a track.

## Using the Disc Navigator to browse the contents of a disc

*(Available only when using the OSD)*

Use the Disc Navigator to browse through the contents of a disc to find the part you want to play.



### Important

- It's not possible to use the Disc Navigator when playing a Video CD in PBC mode, or an unfinalized CD-R/RW disc.

### 1 Press DVD SETUP and select 'Disc Navigator' from the on-screen display.

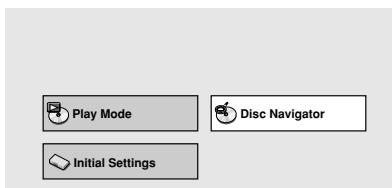

### 2 Select what you want to play.

Depending on the type of disc you have loaded, the Disc Navigator looks slightly different.

The screen for DVD discs shows the titles on the left and the chapters on the right. Select a title, or a chapter within a title.

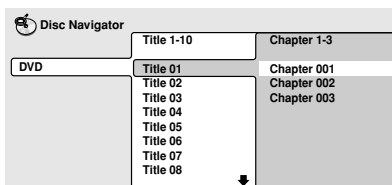

The screen for CDs and Video CDs shows a list of tracks.

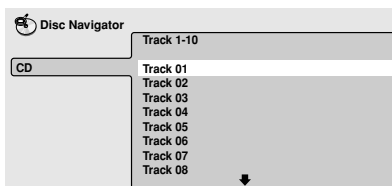

## Playing discs

The screen for an MP3 disc shows the folder names on the left and the track names on the right. Select a folder, or a track within a folder.

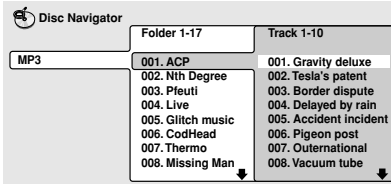

Playback starts after you press **ENTER**.



### Tip

- The disc navigator is not available unless there is a disc loaded.
- Another way to find a particular place on a disc is to use one of the search modes. See *Searching a disc* on page 31.

## Scanning discs

You can fast-scan discs forward or backward at various different speeds.

- 1 During playback, press ◀◀ or ▶▶ (remote) to start scanning.**
- 2 Press repeatedly to increase the scanning speed.**
  - The scanning speed is shown on-screen.
- 3 To resume normal playback, press ▶ (play).**



### Note

- Sound can be heard while scanning audio CDs and MP3 discs.
- MP3 discs have one scanning speed only.
- There are no subtitles displayed and no sound while scanning DVDs and Video CDs.
- Depending on the disc, normal playback may automatically resume when a new chapter is reached on a DVD disc.

## Playing in slow motion

You can play DVDs and Video CDs forward or backward at various slow motion speeds.

- 1 During playback, press II (pause).**
- 2 Press and hold ◀I/◀II or II▶/I▶ until slow motion playback starts.**
  - The slow motion speed is shown on-screen.
  - There is no sound during slow motion playback
- 3 Press repeatedly to change the slow motion speed.**
  - The slow motion speed is displayed on-screen.
- 4 To resume normal playback, press ▶ (play).**

**Note**

- Video CD only supports forward slow motion playback.
- The picture quality during slow motion playback is not as good as during normal playback.
- Depending on the disc, normal playback may automatically resume when a new chapter is reached.

## Frame advance/frame reverse

You can advance or back up a DVD disc frame-by-frame. With Video CDs, you can only use frame advance.

- 1 **During playback, press II (pause).**
- 2 **Press ◀/◀II or II▶/▶ to reverse or advance a frame at a time.**
- 3 **To resume normal playback, press ▶ (play).**

**Note**

- The picture quality when using frame reverse is not as good as frame advance.
- Depending on the disc, normal playback may automatically resume when a new chapter is reached.



## Looping a section of a disc

The A-B Repeat function allows you to specify two points (A and B) within a track (CD and Video CD) or title (DVD) that form a loop which is played over and over.

**Important**

- It's not possible to use A-B Repeat when playing an MP3 disc, a Video CD in PBC mode, an unfinalized CD-R/RW disc, and some DVDs.

- 1 **During playback, press DVD SETUP and select 'Play Mode'.**
- 2 **Select 'A-B Repeat' from the list of functions on the left.**

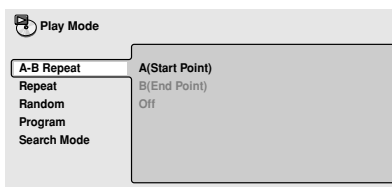

- 3 **Press ENTER on 'A(Start Point)' to set the loop start point.**

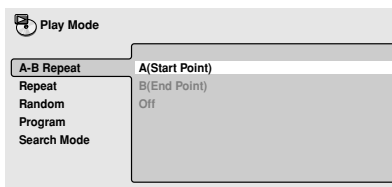



4 Press **ENTER** on 'B(End Point)' to set the loop end point.

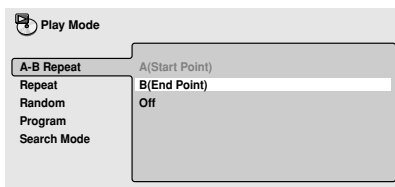

After pressing **ENTER**, playback jumps back to the start point and plays the loop.

- The minimum loop time is 2 seconds.

5 To resume normal playback, select 'Off' from the menu.



**Tip**

- While the loop is being played, you can press **CLEAR** to resume normal playback.

## Using repeat play

There are various repeat play options, depending on the kind of disc loaded. It's also possible to use repeat play together with program play to repeat the tracks/chapters in the program list (see *Creating program lists* on page 28).



**Important**

- It's not possible to use repeat play when playing a Video CD in PBC mode, an unfinalized CD-R/RW disc, and some DVDs.

## Using the OSD

1 During playback, press **DVD SETUP** and select 'Play Mode'.

2 Select 'Repeat' from the list of functions on the left.

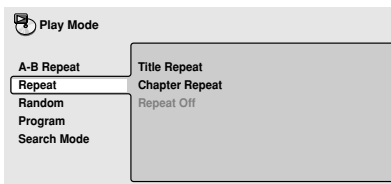

3 Select a repeat play option.

If program play is active, select **Program Repeat** to repeat the program list, or **Repeat Off** to cancel.

For DVD discs, select **Title Repeat** or **Chapter Repeat** (or **Repeat Off**).

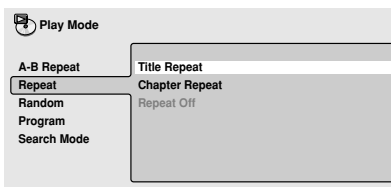

For CDs and Video CDs, select **Disc Repeat** or **Track Repeat** (or **Repeat Off**).

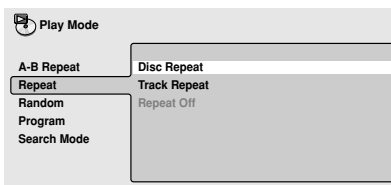

For MP3 discs, select **Disc Repeat**, **Folder Repeat** or **Track Repeat** (or **Repeat Off**).

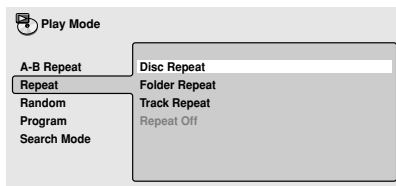

## Using the front panel display

- **During playback, press REPEAT (SHIFT+2) select a repeat play option.** Press repeatedly to cycle through the different options:

- During DVD playback

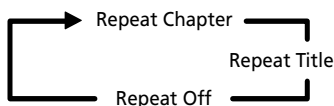

- During CD/VCD/MP3 playback

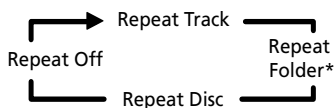

\* Available during MP3 playback only

To stop repeat play, press **CLEAR** at any time.

### Note

- You can't use repeat and random play at the same time.
- If you switch camera angles during repeat play, repeat play is cancelled.

## Using random play

Use the random play function to play titles or chapters (DVD) or tracks (CD, Video CD and MP3 discs) in a random order.

You can set the random play option when a disc is playing or stopped.

### Important

- It's not possible to use random play when playing a Video CD in PBC mode, an unfinalized CD-R/RW disc, and some DVDs.

## Using the OSD

- 1 Press **DVD SETUP** and select 'Play Mode'.
- 2 Select 'Random' from the list of functions on the left.

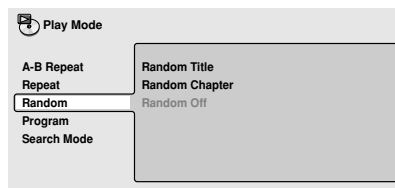

## Playing discs

### 3 Select a random play option.

For DVD discs, select **Random Title** or **Random Chapter** (or **Random Off**)

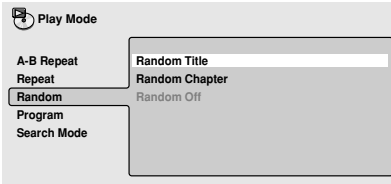

For CDs, Video CDs and MP3 discs, select **On** or **Off** to switch random play of all tracks on the disc (or within an MP3 disc folder) on or off.

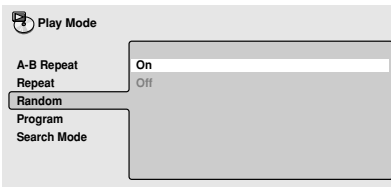

## Using the front panel display

- Press **RANDOM (SHIFT+3)** select a random play option then press **ENTER**.
  - During DVD playback, press repeatedly to cycle through the different options:

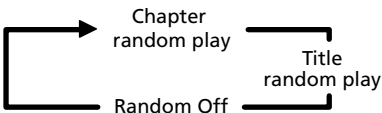

- During CD/VCD/MP3 playback, random play of all tracks on the disc (or within an MP3 disc folder) begins.

To stop random play, press **CLEAR** at any time.



### Tip

- To stop the disc and cancel random playback, press **■** (stop).
- To cancel random playback without stopping playback, press **CLEAR**. The rest of the disc plays out.
- When random play is used with MP3 discs, only tracks from the current folder are played.
- During random play, the **⏮** and **⏭** buttons function a little differently to normal: **⏮** returns to the beginning of the current track/chapter. You can't go back further than this. **⏭** selects another track/chapter at random from those remaining.



### Note

- You can't use random play together with program or repeat play.

## Creating program lists

This feature lets you program the play order of titles/chapters/folders/tracks on a disc.



### Important

- It's not possible to use program play when playing a Video CD in PBC mode, or an unfinalized CD-R/RW disc.

## Using the OSD

If you're playing a DVD disc or a Video CD, you should already be using the OSD to navigate the contents. For CDs and MP3 discs (in cases when you're not using the OSD), see *Using the front panel display* on page 30-31.

### 1 Press DVD SETUP and select 'Play Mode'.



### Tip

- With DVDs and Video CDs, you can also press **PROGRAM (SHIFT+1)** on the remote to skip directly to step 4.

### 2 Select 'Program' from the list of functions on the left.

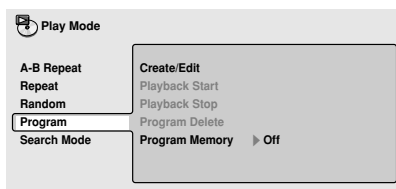

### 3 Select 'Create/Edit' from the list of program options.

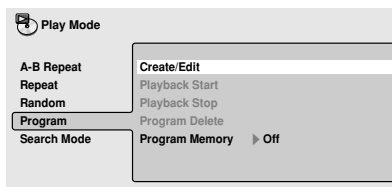

The playlist edit screen that appears depends on the kind of disc loaded.

On the left side is the program list, then to the right is a list of titles (if a DVD disc is loaded), tracks (for CDs and Video CDs), or folder names (for MP3 discs). On the far right is a list of chapters (for DVD) or track names (for MP3).

### 4 Select a title, chapter, folder or track for the current step in the program list.

For a DVD disc, you can add a whole title, or a chapter within a title to the program list.

- To add a title, select the title.

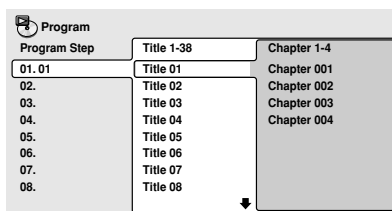

- To add a chapter, first highlight the title, then press **→** (cursor right) and select a chapter from the list.

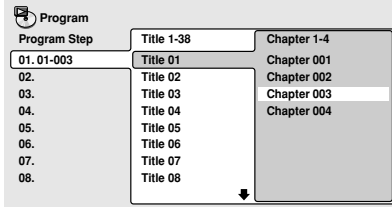

For a CD or Video CD, select a track to add to the program list.

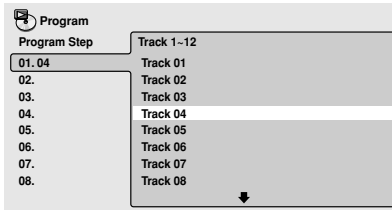

For an MP3 disc, you can add a whole folder, or a track within a folder to the program list.

- To add a folder, select the folder.

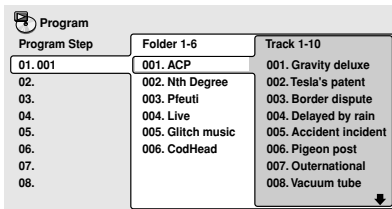

- To add a track, first find the folder, then press **→** (cursor right) and select a track name from the list.

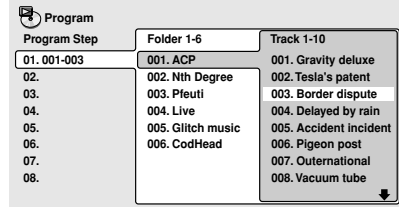

After pressing **ENTER** to select the title/chapter/folder/track, you'll automatically be taken to the next step in the program list.

## 5 Repeat step 4 to build up a program list.

A program list can contain up to 24 steps.

## 6 To play the program list, press **▶** (play).

Program play remains active until you turn off program play (following page), erase the program list (following page), eject the disc or switch off the player.

## Editing program lists using the OSD

After creating a program list, you can add, delete and change steps.

### 1 Press DVD SETUP and select 'Play Mode'.

### 2 Select 'Program' from the list of functions on the left.

- 3 Select 'Create/Edit' from the list of program options.
- 4 To clear a step, highlight the step number and press **CLEAR**.
- 5 To insert a step in the middle of the program list, highlight the step where you want the new step to appear, then select a title/chapter/folder/track to add.  
After pressing **ENTER**, the new step is inserted into the list.
- 6 To add a step to the end of the program list, highlight the next free step then select a title/chapter/folder/track to add.

### Other functions available from the OSD program menu

As well as creating and editing a program list, you can start program play, cancel program play, erase the program list, and memorize a program list from the **Program** menu.

- 1 Press **DVD SETUP** and select 'Play Mode'.
- 2 Select 'Program' from the list of functions on the left.

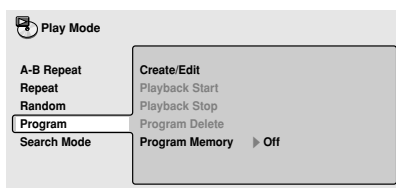

- 3 Select a program play function.
  - **Create/Edit** – See above
  - **Playback Start** – Starts playback of a saved program list
  - **Playback Stop** – Turns off program play, but does not erase the program list
  - **Program Delete** – Erases the program list and turns off program play
  - **Program Memory** (DVD only) – Select **On** to save the program list for the disc loaded. (Select **Off** to cancel the program memory for the disc loaded)



#### Tip

- Program lists are saved for the disc loaded. When you load a disc with a saved program list, program play is automatically turned on.
- You can save program lists for up to 24 discs. After that, the oldest one is replaced with the new one saved.
- To save your program list and exit the program edit screen without starting playback, press **DVD SETUP** (don't press **RETURN**, your program list won't be saved).
- During playback, you can press **CLEAR** at any time to switch off program play.

### Using the front panel display

Even though the OSD is available for CDs and MP3 discs, the front panel display provides enough information to make a program list easily.

## Playing discs

### 1 Make sure the disc is stopped, then press PROGRAM (SHIFT+1).

You're prompted to enter the first track in the program list.

P-00 ▶ 0'00"

### 2 MP3 discs only: Use the number buttons to select a folder for the current step in the program list then press ▶.



#### Tip

- Use the ◀/▶ buttons to choose folder input mode or track input mode and the ▲/▼ buttons to select folder numbers or track numbers.

### 3 Use the number buttons to select a track for the current step in the program list then press ENTER.

P-01 ▶ 3

Wait for the display to prompt you after completing each selection. If you make a mistake, press **CLEAR** to delete the last (most recently) programmed track.

### 4 Repeat steps 2 and 3 to build up a program list.

A program list can contain up to 24 steps.

### 5 To play the program list, press ▶ (play).

Program play remains active until you press ■ (stop), clear the playlist (see below), eject the disc or switch off the player.

## Clearing a track from the program list

### 1 Press PROGRAM (SHIFT+1).

### 2 To clear the most recent track in the program, press CLEAR.

Press repeatedly to clear several steps.

## Clearing the program list

You must clear the program list to program a new one.

- Press **CLEAR** while the disc is stopped.

## Searching a disc

You can search DVD discs by title or chapter number, or by time. CDs can be searched by track number, and Video CDs by track number or time. MP3 discs can be searched by folder or track number.



### Important

- It's not possible to use the search options when playing a Video CD in PBC mode, or an unfinalized CD-R/RW disc.

### 1 Press DVD SETUP and select 'Play Mode'.

### 2 Select 'Search Mode' from the list of functions on the left.

The search options that appear depend on the kind of disc loaded. The screen below shows the DVD search options.

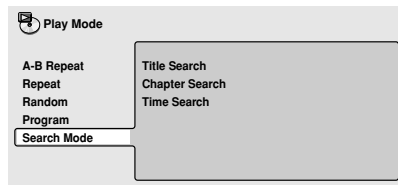

- 3 Select a search mode.
- 4 Use the number buttons to enter a title, chapter, folder or track number, or a time.

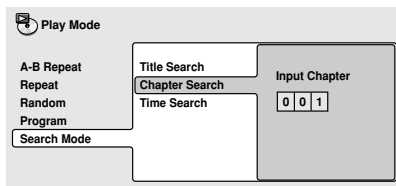

- For a time search, enter the number of minutes and seconds into the currently playing title (DVD) or track (Video CD) you want playback to resume from. For example, press **4, 5, 0, 0** to have playback start from 45 minutes into the disc. For 1 hour, 20 minutes and 30 seconds, press **8, 0, 3, 0**.
- 5 Press **ENTER** to start playback.

## Switching subtitles

Some DVD discs have subtitles in one or more languages; the disc box will usually tell you which subtitle languages are available. You can switch subtitle language anytime during playback.

- Press **SUBTITLE** repeatedly to select a subtitle option.

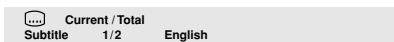

- To set subtitle preferences, see *Subtitle language* on page 52.

## Switching DVD audio languages

When playing a DVD disc recorded with dialog in two or more languages, you can switch audio language anytime during playback.

- Press **AUDIO** repeatedly to select an audio language option.



- To set audio language preferences, see *Audio language* on page 52.

## Switching audio channels when playing a Video CD

When playing a Video CD, you can switch between stereo, just the left channel or just the right channel.

- Press **AUDIO** repeatedly to select an audio channel option.



## Zooming the screen

Using the zoom feature you can magnify a part of the screen by a factor of 2 or 4, while watching a DVD or Video CD.

- During playback, use the **ZOOM** button to select the zoom factor.
  - Normal
  - 2x
  - 4x



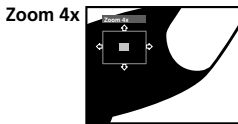
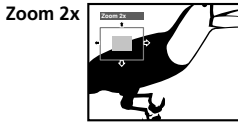
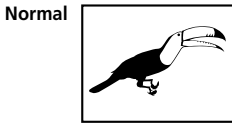

- Since DVD and Video CD have a fixed resolution, picture quality will deteriorate, especially at 4x zoom. This is not a malfunction.

## 2 Use the cursor buttons to change the zoomed area.

You can change the zoom factor and the zoomed area freely during playback.

- If the navigation square at the top of the screen disappears, press **ZOOM** again to display it.

## Switching camera angles

Some DVD discs feature scenes shot from two or more angles—check the disc box for details.

When a multi-angle scene is playing, a icon appears on screen to let you know that other angles are available (this can be switched off if you prefer—see page 54).

- **During playback (or when paused), press ANGLE to switch angle.**



### Note

- It's not possible to use repeat playback when switching camera angles.

## Displaying disc information

### Using the OSD

Various track, chapter and title information, as well as the video transmission rate for DVD discs, can be displayed on-screen while a disc is playing.

- **To show/switch the information displayed, press DVD DISP (SHIFT+8).**

When a disc is playing, the information appears at the top of the screen. Keep pressing **DVD DISP** to change the displayed information.

- DVD displays

Play ▶ DVD					
Title	Current / Total	Elapsed	Remain	Total	
French	11/38	2.05	4.57	7.02	1
Audio	Dolby Digital 3/2:1CH	Subtitle	English		Angle



Play ▶ DVD					
Chapter	Current / Total	Elapsed	Remain	Total	
Tr. Rate	11/38	2.05	4.57	7.02	8.6Mbps



off

- CD and Video CD displays

Play	▶ CD				
Track	Current / Total	Elapsed	Remain	Total	
	2/16	0.23	4.20	4.43	

↓

Play	▶ CD				
Disc		Elapsed	Remain	Total	
		0.23	58.51	57.14	

↓

off

- MP3 disc displays

Play	▶ MP3				
Track	Current / Total	Elapsed	Remain	Total	
	1/17	0.18	12.42	13.00	
Track Name	Ouernternational				

↓

Play	▶ MP3				
Folder	Current / Total				
	2 / 7				
Folder Name	ACP				

↓

off



### Tip

- You can see disc information (number of titles/chapters, tracks, folders and so on from the disc navigator screen. See *Using the disc navigator to browse the contents of a disc* on page 22-23.

## Using the front panel display

You can check various track, chapter and title information on the front panel display while a disc is playing.

- **To show/switch the information displayed, press DVD DISP (SHIFT+8).**

Keep pressing **DVD DISP** to change the displayed information.

- DVD displays

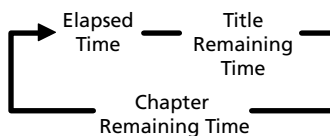

- Video CD displays (except during PBC play)

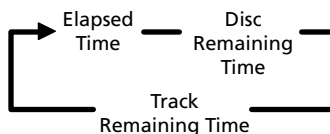

- CD displays

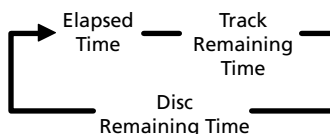

- MP3 disc displays

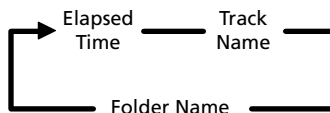

### Tip

- Press **SYSTEM DISP** to switch between the clock and the front panel displays above.

## Choosing stations

The tuner can receive both FM and AM broadcasts, and lets you memorize your favorite stations so you don't have to manually tune in every time you want to listen.

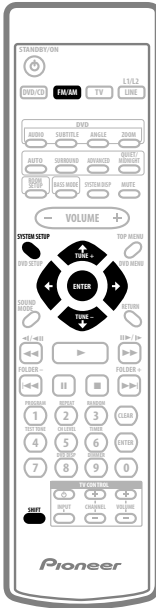

### 1 Press FM/AM (remote) or TUNER (front panel) to switch to the tuner and select the AM or FM band.

Press repeatedly to switch between AM and FM.

### 2 Tune to a frequency.

There are three tuning modes—manual, auto, and high-speed:

**Manual tuning:** Press **TUNE +** or **-** repeatedly to change the displayed frequency.

**Auto tuning:** Press and hold **TUNE +** or **-** until the frequency display starts to move, then release. The tuner will stop on the next station it finds. Repeat to search for other stations.

**High-speed tuning:** Press and hold **TUNE +** or **-** until the frequency display starts to move rapidly. Keep the button held down until you reach the frequency you want. If necessary, fine tune the frequency using the manual tuning method.

## Improving poor FM reception

If you're listening to an FM station in stereo but the reception is weak, you can improve the sound quality by switching to mono.

### 1 Press SYSTEM SETUP (SHIFT+DVD SETUP).

### 2 Use the ← / → (cursor left/right) buttons to choose FM MONO/AUTO

### 3 Use the ↑ / ↓ (cursor up/down) buttons to select MONO then press ENTER.

The **MONO** indicator lights when the tuner is in mono reception mode.

Select **AUTO** in step 3 to switch back to auto-stereo mode (the stereo indicator lights when receiving a stereo broadcast).

## Memorizing stations

You can save up to 30 station presets so that you always have easy access to your favorite stations without having to tune in manually each time.

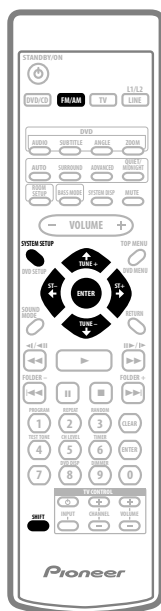

### Note

- If the unit is unplugged from the power supply completely, saved stations will remain for several days, after which you'll have to save them again.

### 1 Tune to an AM or FM radio station.

For the FM band, select mono or auto-stereo reception as necessary. This setting is saved along with the preset.

### 2 Press SYSTEM SETUP (SHIFT+DVD SETUP).

### 3 Use the ←/→ (cursor left/right) buttons to choose ST. MEMORY then press ENTER.

### 4 If necessary, use the ↑/↓ (cursor up/down) buttons to select the station preset you want.

There are 30 preset locations; each can store one station preset.

### 5 Press ENTER to save the station preset.

## Listening to station presets

### 1 Make sure the TUNER function is selected.

### 2 Use the ST +/- buttons to select a station preset.

## An introduction to RDS

*European model only*

Radio Data System, or RDS as it's usually known, is a system used by FM radio stations to provide listeners with various kinds of information—the name of the station and the kind of show they're broadcasting, for example. This information shows up as text on the display, and you can switch between the kind of information shown. Although you don't get RDS information from all FM radio stations, you do with most.

Probably the best feature of RDS is that you can search automatically by type of program. So, if you felt like listening to jazz, you could search for a station that's broadcasting a show with the program type, **JAZZ**. There are around 30 such program types, including various genres of music, news, sport, talk shows, financial information, and so on.

This system lets you display three different kinds of RDS information: Radio Text, Program Service Name, and Program Type.

Radio Text (**RT**) is messages sent by the radio station. These can be anything the broadcaster chooses—a talk radio station might give out its telephone number as RT, for example.

Program Service Name (**PS**) is the name of the radio station.

Program Type (**PTY**) indicates the kind of program currently being broadcast.

This unit can search for and display the following program types:

<b>NEWS</b>	News
<b>AFFAIRS</b>	Current affairs
<b>INFO</b>	General information

<b>SPORT</b>	Sports
<b>EDUCATE</b>	Educational material
<b>DRAMA</b>	Radio drama
<b>CULTURE</b>	Arts and culture
<b>SCIENCE</b>	Science and technology
<b>VARIED</b>	Usually talk-based material, such as quiz shows or interviews.

<b>POP M</b>	Pop music
<b>ROCK M</b>	Rock music
<b>EASY M</b>	Easy listening music
<b>LIGHT M</b>	'Light' classical music
<b>CLASSICS</b>	'Serious' classical music
<b>OTHER M</b>	Other music not fitting any of the above categories

<b>WEATHER</b>	Weather reports
<b>FINANCE</b>	Finance and business
<b>CHILDREN</b>	Children's entertainment
<b>SOCIAL</b>	Social affairs
<b>RELIGION</b>	Religious programming
<b>PHONE IN</b>	Phone-in talk shows
<b>TRAVEL</b>	Travel
<b>LEISURE</b>	Leisure interests and hobbies

<b>JAZZ</b>	Jazz music
<b>COUNTRY</b>	Country music
<b>NATION M</b>	Popular music in a language other than English
<b>OLDIES</b>	Popular music from the '50s

<b>FOLK M</b>	Popular music from the '50s
<b>DOCUMENT</b>	Documentaries

In addition, there is a program type, **ALARM!**, used for exceptional emergency announcements. You can't search for this, but the tuner will switch automatically to this RDS broadcast signal.

## Using the RDS display

*European model only*

To display the different types of **RDS** information available (**RT**, **PS** and **PTY** as explained on the previous page), press **SYSTEM DISP** on the remote control to cycle through the types of **RDS** information.

Each press changes the display as follows:

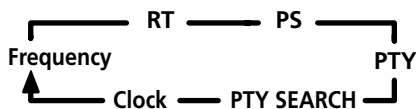

### Note

- If any noise is picked up while displaying the RT scroll, some characters may be displayed incorrectly.
- If you see **NO DATA** in the RT display, it means no RT data is being transmitted from the broadcast station. The display will automatically switch to the PS data display. If no PS data is transmitted from the station, the frequency will be displayed.
- In the PTY display, there are cases where **NO DATA** or **NO TYPE** is shown. If this happens, the PS display is shown after a few seconds.
- This unit converts lower case characters transmitted by broadcast stations to upper case characters.

## Searching for RDS programs

*European model only*

One of the most useful features of RDS is the ability to search for a particular kind of radio program. You can search for any of the program types (listed on the previous page).

### 1 Use the **BAND** button to select the **FM** band.

RDS is only broadcast on FM.

### 2 Press **SYSTEM DISP** repeatedly until **PTY SEARCH** appears in the display.

### 3 Use the **↑/↓** (cursor up/down) buttons to select the program type you want to hear.

### 4 Press **ENTER** to search for the program type.

The system starts searching through the station presets for a match. When it finds one, the search stops and the station plays for five seconds.

### 5 If you want to keep listening to the station, press **ENTER** within the 5 seconds.

If you don't press **ENTER**, searching resumes.



### Note

- RDS searches station presets only.



- 3 Use the **↑/↓** (cursor up/down) buttons to adjust the setting.
- 4 Repeat steps 3 and 4 to make other settings.
- 5 When you're done, press **SYSTEM SETUP (SHIFT+DVD SETUP)** to exit.

**Note**

- The setting display is automatically exited after 20 seconds of inactivity.

**Front speaker distance setting**

- Default setting: **1.8 m**

Sets the distance from the front speakers to the listening position.

- Use **↑/↓** to set the distance of the front speakers from the main listening position (within a 9 meter range).

**Center speaker distance setting**

- Default setting: **1.5 m**

The center speaker is normally placed directly in the front of the listening room and closer to the listening position than the front speakers. This means that the sound from the center speaker will be heard before the front speakers. To prevent this, set the center speaker distance setting to delay the sound from the center speaker so that the sound from the front and center speakers will be heard at the same time.

- Use **↑/↓** to set the distance of the center speaker from the main listening position (within a 9 meter range).

**Surround speaker distance setting**

- Default setting: **1.8 m**

Like the center speaker, you should set the distance of the surround speakers accurately to hear sounds coming from both front and surround speakers at the same time.

- Use **↑/↓** to set the distance of the surround speakers from the main listening position (within a 9 meter range).

**Dynamic range control setting**

- Default setting: **OFF**

Dynamic range is the difference between the loudest and softest sounds in any given signal. With this setting, you can compress the dynamic range, so that low level sounds can be heard more easily (sounding relatively louder) yet louder sounds won't be too overbearing.

- Press **↑/↓** to set the dynamic range control (**OFF, MID** or **HIGH**).

**Note**

- When the volume level is increased, set to **OFF**.
- When listening at low volumes, set to **HIGH** for maximum dynamic range compression.
- Dynamic range control is effective only when a Dolby Digital signal is being played back.



## Dual mono setting

- Default setting: **L-CH1 R-CH 2**

The dual mono setting can only be used when listening to Dolby Digital discs with dual mono encoding. These discs are not widely used, but are sometimes used to separate the backing track from the vocals on karaoke discs. With this setting you can choose which channel in the dual mono setting you want to listen to.

You will hear the channel you have selected (either **CH1** or **CH2**) through your center speaker. If surround sound is switched off, you will hear the channel you have selected through both front speakers. In the **L-CH1 R-CH 2** setting, the left front speaker will play channel 1 and the right front speaker will play channel 2.

- Use **↑/↓** to cycle through the possible dual mono settings.

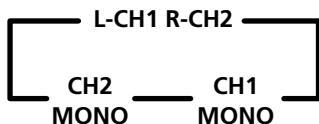

## LFE attenuator setting

- Default setting: **0 dB**

Dolby Digital and DTS audio sources include ultra-low bass tones. Set the LFE attenuator as necessary to prevent the ultra-low bass tones from distorting the sound from the speakers.

- Use **↑/↓** to set the attenuation level (**0 dB, 10 dB or OFF**).

## Setting the relative volume level of each channel

- Default setting (European model only):  
**RS/LS: +2dB**  
**SW: +1dB**  
**All other channels: 0dB**
- Default setting (U.S. model only):  
**All channels: 0dB**
- Default setting (all other models):  
**SW: -2dB**  
**All other channels: 0dB**

For best surround sound playback, you should set the relative channel levels from the main listening position. You can set separate levels for each surround mode.

### 1 Press SURROUND repeatedly to select a multi-channel listening mode.

The Surround mode can be set to anything but **AUTO** or **STEREO**.

### 2 Press TEST TONE (SHIFT+4) to hear the test tone.

The test tone is output in the following order:

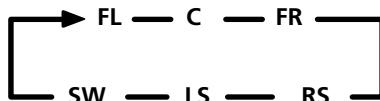

### 3 Press VOLUME +/- to adjust the volume to an appropriate level.

### 4 Use the ↑/↓ (cursor up/down) buttons to adjust the speaker levels in turn.

You should hear the test tone at the same volume from each speaker when seated in the main listening position. The channel level range is  $\pm 10$  dB.

### 5 When you're done, press TEST TONE (SHIFT+4) to turn off the test tone.

**Tip**

- The speaker volume can be adjusted while listening to any sound source you want by pressing **CH LEVEL (SHIFT+5)** and then using the **↑/↓** (cursor up/down) buttons to adjust the channel levels. After you're finished with one channel, use the **←/→** (cursor left/right) buttons to move to the next.

**Note**



- Since the subwoofer transmits an ultra-low frequency its sound may seem quieter than it actually is.



## Using the multi-channel sound modes

There are three basic multi-channel sound modes: Auto, Surround and Advanced Surround. The Stereo mode (available in all three modes) bypasses the multi-channel sound modes and downmixes multi-channel sources to your two-front speakers.

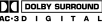
### Auto

The **AUTO** mode automatically decodes Dolby Digital, DTS or Dolby Surround sources. You can identify Dolby Digital software by the  or  marks. Most Dolby Surround software is marked , but unmarked software may also incorporate Dolby Surround.

### Surround modes

The surround mode options (below) can add surround sound to regular stereo sources.

Choose one of the following to add depth to a 2 channel source:

### Pro Logic

This mode gives 4.1 channel surround sound. It is less sensitive to the quality of the source material, so may be useful when Pro Logic II Movie/ Music modes do not give good results.

### Pro Logic II Movie

This mode gives 5.1 channel surround sound. It is suitable for movies, especially those recorded in Dolby Surround. The channel separation and movement of surround effects is comparable to Dolby Digital 5.1.

### Pro Logic II Music

This mode gives 5.1 channel surround sound and is suitable for music. Compared to Pro Logic II Movie, the surround effect is more enveloping.

## Advanced Surround modes

These are designed to be used with multi channel surround sound audio/visual sources (like DVDs and LDs). Most Advanced Surround modes are designed to be used with film soundtracks, but some modes are also suited for music sources. Try different settings with various soundtracks to see which you like.

### Advanced Music

Simulates the acoustic environment of a large concert hall and is suitable for music or musical sources marked .



### Advanced Movie

Simulates the relaxed environment of a movie theater, and is suitable for watching movies on sources marked .



### Virtual Surround Back

The Virtual Surround Back effect simulates 6.1 surround channel listening, giving the impression that there is a surround back speaker in your system when listening to a 5.1 channel source.

### Expanded

This mode is especially designed to give sound depth to stereo sources. The overall effect builds a dynamic and broad sound space, allowing two-channel (stereo) signals to imitate a five speaker sound. Use with Dolby Pro Logic for a stereo surround effect. You can also use with Dolby Digital sources for a wider stereo field than the Surround modes.

### TV Surround

You can use this mode to give surround sound to mono or stereo TV audio sources.

### Virtual Surround

When you select this mode, you will hear a surround sound effect produced from the two front speakers only. When selected, you won't hear any sound from the other speakers in your system.

### 5-Channel Stereo

This can be selected to give powerful multi-channel sound to a stereo source by giving equal power to all of the speakers in your setup. It is particularly well-suited to music sources with deep bass and a strong rhythmic feel.

### Phones Surround

This is very similar to the Virtual Surround mode, and is available when you're listening to the headphones to create an overall surround sound effect.

### Stereo

When you select **STEREO** (available in both the Surround and Advanced surround modes), you will hear the source through just the front left and right speakers. Dolby Digital and DTS multi-channel sources are downmixed to stereo.

The audio plays according to the surround setup settings and you can still use the tone control (**SOUND MODE**) functions.

## Listening to multi-channel playback

Dolby Pro Logic, Dolby Digital and DTS signal processing is done automatically corresponding to the input signal.

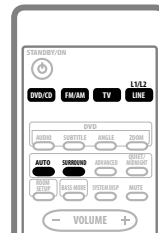

**1 Select the source you want to playback.**

**2 Press AUTO.**

For multi-channel sources, Dolby/DTS decoding is selected automatically according to the source and **AUTO** shows in the display.

Pressing **SURROUND** repeatedly during playback of a multi-channel source will cycle through the following menu:



Selecting **STEREO** downmixes a multi-channel source to your two-front speakers.

For a two channel source, you can press **SURROUND** repeatedly to select between the three Pro Logic II modes (below).

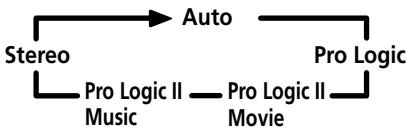

Refer to page 43 for more details about each mode.

**3 Start playback of the component you selected in step 1.**



**Note**

- When playing 96 kHz digital signal disc formats, you can only use the **STEREO** listening mode.
- When the headphones are connected, you can only use the **STEREO** listening mode.

## Listening to a stereo source

When **AUTO** is selected, a stereo source is detected automatically and plays through the front speakers only. To listen to a stereo source with surround sound, see *Listening to multi-channel playback* on the previous page.

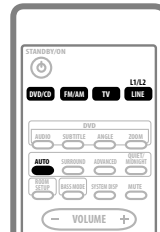

**1 Select the stereo source you want to playback.**

**2 Press AUTO.**

**3 Start playback of the component you selected in step 1.**

## Using Advanced Surround

Use the Advanced Surround modes to add DSP effects to a multi-channel source.



- Press **ADV. SURR** repeatedly to choose one of the sound options.

Each press changes the display as follows:

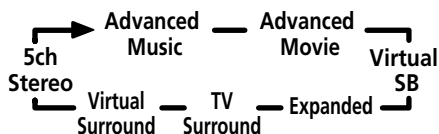

Refer to pages 43–44 for more details about each surround effect.



### Note

- The Advanced Movie, Advanced Music, Expanded, TV Surround and Virtual Surround effects of Dolby/DTS can be adjusted in the range of 10 to 90 (the default setting is 70) using the **SOUND MODE** button on the remote (see the next page). The effect level can be set for each of these Advanced Surround modes. The Surround modes cannot be changed.

## Using the headphones with Advanced Surround

- When headphones are connected you can only use the **PHONES SURROUND** mode.

### Adjusting the bass and treble

- Default setting (U.S. model only):  
**TREBLE: 0dB**  
**BASS: 0dB**
- Default setting (all other models):  
**TREBLE: -2dB**  
**BASS: 0dB**

To help you get the sound you want you can increase or reduce the bass and treble.

#### 1 Press **SOUND MODE**.

Make sure that the **MIDNIGHT** and **QUIET** modes are off when you do this.

#### 2 Use the **←/→** (cursor left/right) buttons to select **BASS** or **TREBLE**.

#### 3 Use the **↑/↓** (cursor up/down) buttons to adjust the sound.

The bass and treble can be adjusted from -3 to +3.

#### 4 Press **ENTER** to confirm.

### Adjusting the effect level

- Default setting: **70**

You can adjust the effect level of the Advanced Surround mode to get the sound that you want.

#### 1 Press **SOUND MODE**.

Make sure that the **ADVANCED SURROUND** mode is on when you do this.

#### 2 Use the **←/→** (cursor left/right) buttons to select **EFFECT**.

#### 3 Use the **↑/↓** (cursor up/down) buttons to adjust the effect level.

The DSP effect level can be adjusted from 10 (min) to 90 (max).

#### 4 Press **ENTER** to confirm.



#### Note

- This doesn't work with the 5-Channel Stereo or the Virtual SB mode.

### Boosting the bass level

- Default setting: **OFF**

If you want to bring up the low end for certain kinds of music or sound sources, you can use the bass mode to do so.

#### • Press **BASS MODE** repeatedly to choose an option that fits the source you're listening to.

- **MUSIC** - Can be used with music to give a deeper bass sound
- **CINEMA** - Good for action movies or movies with lots of sound effects
- **P. BASS** - Can be used with music sources to bring the beat of the music (or soundtrack) to the forefront
- **OFF**



#### Note

- You can't use the bass mode when the headphones are connected.

*Not applicable to the European model:*

- The default setting for multi-channel (5.1 channel) listening is **CINEMA**.

## Using Midnight and Quiet listening

- Default setting: **OFF**

The Midnight listening feature allows you to hear effective surround sound of movies at low volume levels. The effect automatically adjusts according to the volume at which you're listening.

The Quiet listening feature reduces excessive bass or treble in a sound source. You can use this feature if the music is a little bit harsh and you would like a smoother sound.

- **Press QUIET/MIDNIGHT repeatedly to switch between QUIET, MIDNIGHT and OFF.**

## Muting the sound

Use the mute button if you need to momentarily turn off any sound coming out of the speakers.

- **Press MUTE to switch off the volume.** To switch the sound back on, adjust the volume or press **MUTE** again.

## Reducing the TV and line signal levels

- Default setting: **OFF**

Some sources may produce a high signal level which may produce unpleasant distortion from the speakers. In such cases, you may need to reduce the signal level of the auxiliary source (connected to the TV or line 1 inputs) by switching on the attenuator.

- 1 Switch the system into standby.**
- 2 Press SYSTEM SETUP (SHIFT + DVD SETUP).**
- 3 Use the ←/→ buttons to select TV ATT or LINE1 ATT.**
- 4 Use the ↑/↓ buttons to select ATT 6dB, ATT 10dB or OFF.**

Use the **ATT 10dB** option for sources with especially high signal levels, and the **ATT 6dB** option for other source levels causing distortion.

- 5 Press ENTER to confirm.**





**Tip**

- You can check the timer settings in standby by pressing **TIMER (SHIFT+6)**.

## Turning the wake-up timer on/off

If the wake-up timer is active, it will switch on everyday at the time you have set. Here's how to turn it on or off:

- 1 Press **TIMER (SHIFT+6)**.
- 2 Use the **←/→** buttons to select **WAKE-UP** then press **ENTER**.
- 3 Use the **↑/↓** buttons to select **TIMER ON** or **TIMER OFF**.
  - You must have the timer set (see above) to select **ON**. The wake-up timer switches on and off according to your previous settings.
- 4 Press **ENTER**.

**Note**

- The wake-up timer will automatically be canceled if the clock is reset.

## Setting the sleep timer

The sleep timer switches off the system after a specified time so you can fall asleep without worrying about it.

**Note**

- If you set the sleep timer while either the wake-up timer is active, the earlier switch off time takes priority.



- 1 Press **TIMER (SHIFT+6)**.
- 2 Use the **←/→** buttons to select **SLEEP TIMER** then press **ENTER**.
- 3 Use the **↑/↓** buttons to select a switch-off time then press **ENTER**.

Choose between the following options:

- AUTO** – System switches off 1 minute after the current source has finished playing. You can only set this during CD playback. CD repeat play does not work with the automatic sleep timer.
- SLEEP 90** – system switches off after 90 minutes
- SLEEP 60** – system switches off after an hour
- SLEEP 30** – system switches off after 30 minutes
- OFF** – cancels the sleep timer

- 4 To check how much time is left, repeat steps 1 and 2.

The remaining time is displayed momentarily.

## Using the Initial Settings menu

The Initial Setup menu gives you complete control in setting up your system, including video output settings and parental lock settings, among others.

If an option is grayed out it means that it cannot be changed at the current time. This is usually because a disc is playing. Stop the disc, then change the setting.

### 1 Press DVD SETUP and select 'Initial Settings' from the on-screen display.

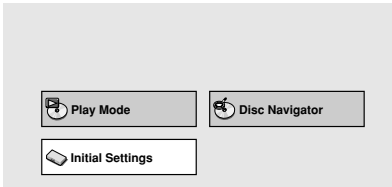

### 2 Select the setup category from the list on the left, then select an item from the menu list to the right.

### 3 Make the setting you want.

#### Note

- The language options shown in the on-screen display illustrations on the following pages may not correspond to those available in your country or region.

## Video settings

### TV Screen

- Default: **4:3 (Letterbox)**

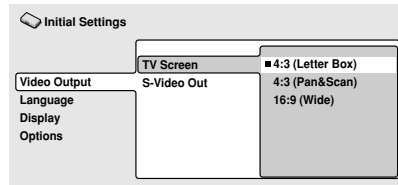

If you have a widescreen TV, select the **16:9 (Wide)** setting—widescreen DVD software is then shown using the full screen area. When playing software recorded in standard (4:3) format, the settings on your TV will determine how the material is presented—see the manual that came with your TV for details on what options are available.

If you have a conventional (standard) TV, select either **4:3 (Letter Box)** or **4:3 (Pan & Scan)**. In Letter Box mode, widescreen software is shown with black bars at the top and bottom of the screen. Pan & Scan chops the sides off widescreen material to make it fit the 4:3 screen (so even though the picture looks larger on the screen, you're actually seeing less of the movie). See also *Screen sizes and disc formats* on page 66.

## S Video Out

- Default setting: **S2**

You only need to make this setting if you connected this system to your TV using an S-Video cord.

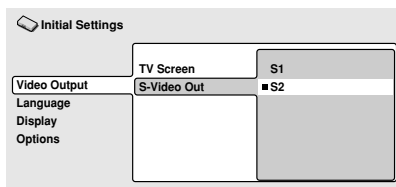

If you find that the picture is stretched or distorted on the default **S2** setting, try changing it to **S1**.

## Language settings

### Audio Language

- Default Setting: **English**

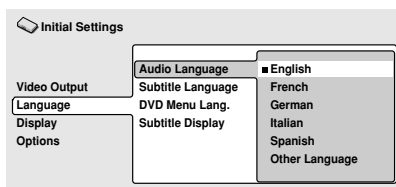

This setting is your preferred Audio Language for DVD discs. If the language you specify here is recorded on a disc, the system automatically plays the disc in that language.

The DVD format recognizes 136 different languages. Select **Other Language** if you want to specify a language other than those listed, then follow the on-screen display to select a language. You may also want to refer to the Language code list on page 67.



### Tip

- You can switch between the languages recorded on a DVD disc any time during playback using the **AUDIO** button. (This does not affect this setting.) See *Switching DVD audio languages* on page 32.

### Subtitle Language

- Default Setting: **English**

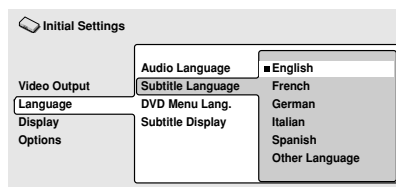

This setting is your preferred subtitle language for DVD discs. If the language you specify here is recorded on a disc, the system automatically plays the disc with those subtitles.

The DVD format recognizes 136 different languages. Select **Other Language** if you want to specify a language other than those listed, then follow the on-screen display to select a language. You may also want to refer to the Language code list on page 67.



### Tip

- You can change or switch off the subtitles on a DVD disc any time during playback using the **SUBTITLE** button. (This does not affect this setting.) See *Switching subtitles* on page 32.

## DVD Menu Language

- Default Setting: **w/Subtitle Lang.**

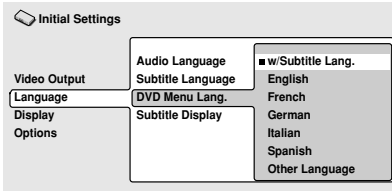

Some multilingual discs have disc menus in several languages. This setting specifies in which language the disc menus should appear. Leave on the default setting for menus to appear in the same language as your Subtitle Language—see the previous page.

The DVD format recognizes 136 different languages. Select **Other Language** if you want to specify a language other than those listed, then follow the on-screen display to select a language. You may also want to refer to the Language code list on page 67.

## Subtitle Display

- Default Setting: **On**

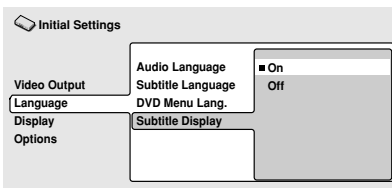

When set to **On**, the player displays subtitles according to the Subtitle Language. Set to **Off** to switch subtitles off altogether (although see Subtitle Off on this page for special cases).

## Display settings

### OSD Language

- Default setting: **English**

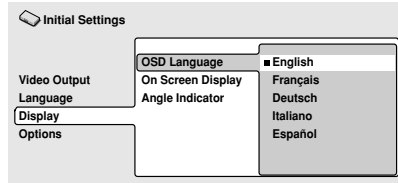

This sets the language of this player's on-screen displays.

### On Screen Display

- Default setting: **On**

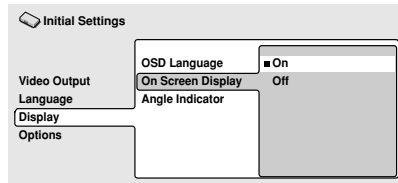

This sets whether operation displays are shown on-screen (**PLAY**, **RESUME**, **SCAN** and so on.)

## Angle Indicator

- Default setting: **On**

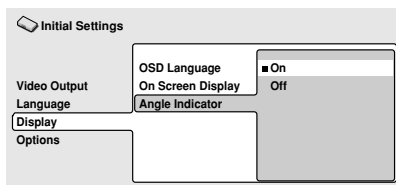

If you prefer not to see the camera icon on-screen during multi-angle scenes on DVD discs, change this setting to **Off**.

## Options

### Parental Lock

- Default level: **Off**
- Default password: **none**
- Default country code: **us (2119)**

Some DVD Video discs feature a Parental Lock level. If your player is set to a lower level than the disc, the disc won't play. This gives you some control about what your children watch on your DVD player.

Some discs also support the Country Code feature. The player does not play certain scenes on these discs, depending on the country code you set.

Before you can set the Parental Lock level or the Country Code you must register a password. As the password owner, you can change the Parental Lock level or Country Code whenever you like. You can also change the password.

### Note

- Not all discs that you may consider inappropriate for your children use the Parental Lock feature. These discs will always play without requiring the password first.
- If you forget your password, you'll need to reset the system to its factory settings (page 57), then register a new password.

## Registering a new password

You must register a password before you can change the Parental Lock level or enter a Country Code.

### 1 Select 'Password'.

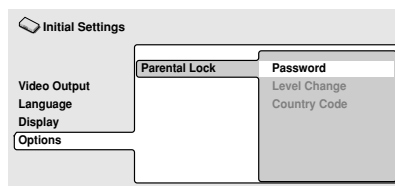

### 2 Use the number buttons to enter a 4-digit password.

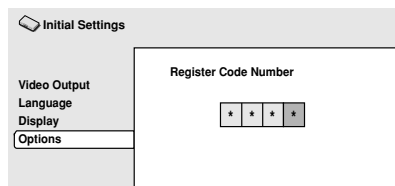

The numbers you enter show up as asterisks (\*) on-screen.

### 3 Press ENTER to register the password and return to the Options menu screen.

If you forget your password, you can reset the system then register a new one. See page 61 for how to reset the player.

### Changing your password

To change your password, confirm your existing password then enter a new one.

#### 1 Select 'Password Change'.

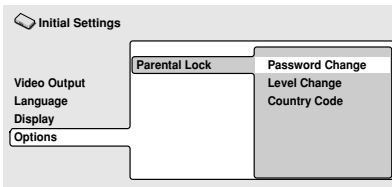

#### 2 Use the number buttons to enter your existing password, then press ENTER.

- The numbers appear as asterisks as you enter them.

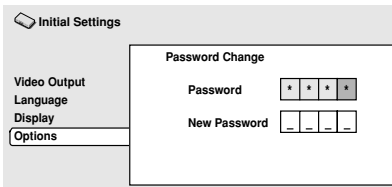

#### 3 Enter a new password.

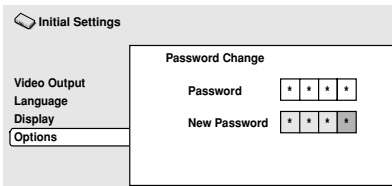

### 4 Press ENTER to register the new password and return to the Options menu screen.

### Setting/changing the Parental Lock level

#### 1 Select 'Level Change'.

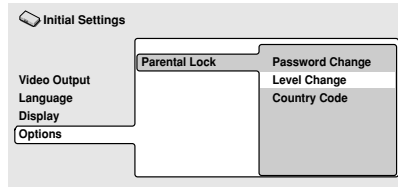

#### 2 Use number buttons to enter your password, then press ENTER.

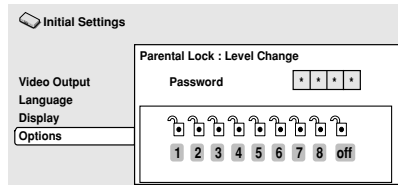

#### 3 Select a new level.

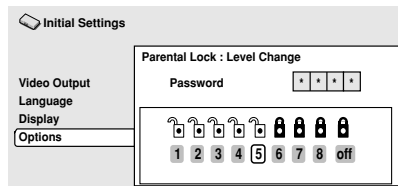

Press ← (cursor left) repeatedly to lock more levels (more discs will require the password); press → (cursor right) to unlock levels. You can't lock level 1.

#### 4 Press ENTER to set the new level and return to the Options menu screen.

### Setting/changing the Country Code

You may also want to refer to the Country code list on page 67.

#### 1 Select 'Country Code'.

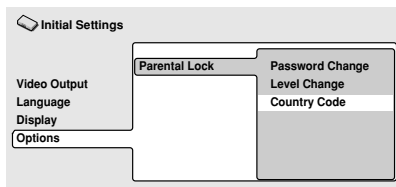

#### 2 Use number buttons to enter your password, then press ENTER.

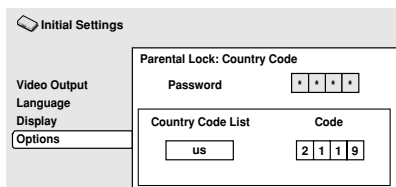

#### 3 Select a country code.

There are two ways you can do this.

- Select by code letter: Use ↑/↓ (cursor up/down) to change the country code.

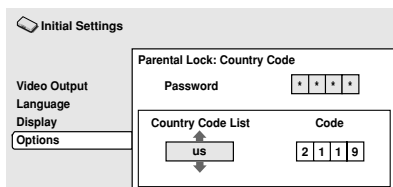

- Select by code number: Press → (cursor right) then use the number buttons to enter the 4-digit country code (you can find the Country code list on page 67).

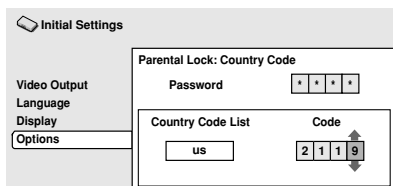

#### 4 Press ENTER to set the new Country Code and return to the Options menu screen.



## Switching off the demo

- Default setting: **DEMO ON**

This unit has an automatic demo feature that starts when the unit is plugged in for the first time. Here's how to turn it off:

- 1 **Switch the system into standby.**
- 2 **Press SYSTEM SETUP (SHIFT+DVD SETUP).**
- 3 **Use the ←/→ buttons to select DEMO mode (Default setting: DEMO ON).**  
The current setting is shown in the display.
- 4 **Use the ↑/↓ buttons to select DEMO OFF then press ENTER to confirm.**



### Note

- After setting the clock, the demo mode switches off automatically.

## Dimming the display

- **Press DIMMER (SHIFT+9) to alternate between brightness levels on the display.**

## Changing the frequency step

*Not applicable to the European model.*

- Default setting (U.S. model): **AM 10k**
- Default setting (all other models): **AM 9k**

If you find that you can't tune into stations successfully, the frequency step may not be suitable for your country/region. Here's how to switch the setting:

- 1 **Switch the system into standby.**
- 2 **Press SYSTEM SETUP (SHIFT+DVD SETUP).**

- 3 **Use the ←/→ buttons to select AM 9k / AM 10k.**

The current setting is shown in the display.

- 4 **Use the ↑/↓ buttons to select AM 9k or AM 10k then press ENTER to confirm.**

## Setting the TV format

*Not applicable to the U.S. model.*

- Default setting : **AUTO**

The default setting of this unit is **AUTO**, and unless you notice that the picture is distorted when playing some discs, you should leave it set to **AUTO**.

If you experience picture distortion with some discs, set the TV system to match your country or region.

- 1 **Switch the system into standby.**
- 2 **Press SYSTEM SETUP (SHIFT+DVD SETUP).**

- 3 **Use the ←/→ buttons to select TV system (Default setting: AUTO).**

The current TV format is shown in the display.

- 4 **Use the ↑/↓ buttons to select either AUTO, PAL, or NTSC then press ENTER to confirm.**

## Resetting the unit

Use this procedure to reset all the player's settings to the factory default.

- 1 **Switch the player into standby.**
- 2 **Press and hold down the ■ (stop) button on the front panel until the unit switches on (about 8 seconds).**

All the player's settings are now reset, and you should see the 'Let's Get Started' screen.

## Child Lock

- Default setting: **LOCK OFF**

This system has a child lock feature that makes the front panel buttons and controls inoperative. This is useful when you've set the wake-up timer and don't want the unit switched on before it activates.

- 1 Switch the system into standby.**
- 2 Press SYSTEM SETUP (SHIFT+DVD SETUP).**
- 3 Use the ←/→ buttons to select LOCK ON / LOCK OFF.**  
The current setting is shown in the display.
- 4 Use the ↑/↓ buttons to select LOCK ON or LOCK OFF.**
- 5 Press ENTER to confirm.**

### Using discs with this unit

#### Handling discs

When holding discs of any type, take care not to leave fingerprints, dirt or scratches on the disc surface. Hold the disc by its edge or by the center hole and edge.

Damaged or dirty discs can affect playback performance. Take care also not to scratch the label side of the disc. Although not as fragile as the recorded side, scratches can still result in a disc becoming unusable.

Should a disc become marked with fingerprints, dust, etc., clean using a soft, dry cloth, wiping the disc lightly from the center to the outside edge as shown in the diagram below.

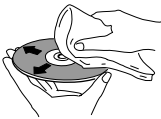

*Wipe lightly from the center of the disc using straight strokes.*



*Don't wipe the disc surface using circular strokes.*

If necessary, use a cloth soaked in alcohol, or a commercially available CD/DVD cleaning kit to clean a disc more thoroughly. Never use benzene, thinner or other cleaning agents, including products designed for cleaning vinyl records.

#### Storing discs

Although CDs and DVD discs are more durable than vinyl records, you should still take care to handle and store discs correctly. When you're not using a disc, return it to its case and store upright. Avoid leaving discs in excessively cold, humid, or hot environments (including under direct sunlight).

Don't glue paper or put stickers onto the disc, or use a pencil, ball-point pen or other sharp-tipped writing instrument. These could all damage the disc.



For more detailed care information see the instructions that come with discs.

Do not load more than one disc into the player at a time.

#### Discs to avoid

Discs spin at high speed inside the player. If you can see that a disc is cracked, chipped, warped, or otherwise damaged, don't risk using it in your player—you could end up damaging the unit.

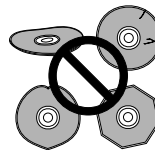

This unit is designed for use with conventional, fully circular discs only. Use of shaped discs is not recommended for this product. Pioneer disclaims all liability arising in connection with the use of shaped discs.

## Proper installation and maintenance of this unit

### Hints on installation

We want you to enjoy using this unit for years to come, so please bear in mind the following points when choosing a suitable location for it:

#### Do...

- ✓ Use in a well-ventilated room.
- ✓ Place on a solid, flat, level surface, such as a table, shelf or stereo rack.

#### Don't...

- ✗ Use in a place exposed to high temperatures or humidity, including near radiators and other heat-generating appliances.
- ✗ Place on a window sill or other place where the player will be exposed to direct sunlight.
- ✗ Use in an excessively dusty or damp environment.
- ✗ Place directly on top of an amplifier, or other component in your stereo system that becomes hot in use.
- ✗ Use near a television or monitor as you may experience interference—especially if the television uses an indoor antenna.
- ✗ Use in a kitchen or other room where the player may be exposed to smoke or steam.
- ✗ Use on a thick rug or carpet, or cover with cloth—this may prevent proper cooling of the unit.
- ✗ Place on an unstable surface, or one that is not large enough to support all four of the unit's feet.

## Cleaning the pickup lens

The DVD player's lens should not become dirty in normal use, but if for some reason it should malfunction due to dust or dirt, consult your nearest Pioneer authorized service center. Although lens cleaners for CD players are commercially available, we do not recommend using them since some may damage the lens.

## Problems with condensation

Condensation may form inside the player if it is brought into a warm room from outside, or if the temperature of the room rises quickly. Although the condensation won't damage the player, it may temporarily impair its performance. For this reason you should leave it to adjust to the warmer temperature for about an hour before switching on and using.

## Moving the unit

If you need to move the unit, first press **STANDBY/ON** on the front panel to turn the player off. Wait for **GOOD BYE** to disappear from the display, then unplug the power cord. Never lift or move the unit during playback—discs rotate at a high speed and may be damaged.



#### Note

- Unplugging the unit before **GOOD BYE** completely disappears from the display may cause the system to return to the factory settings.

## Additional connections

### Connecting external antennas

#### External AM antenna

Use 5–6 meters (15–18 feet) of vinyl-insulated wire and set up either indoors or outdoors. Leave the AM loop antenna connected.

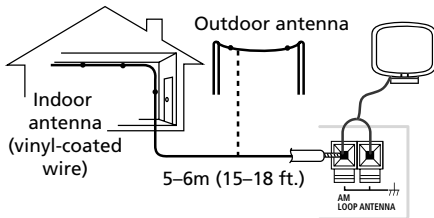

#### External FM antenna

Use 75Ω coaxial cable to hook up an external FM antenna.

#### European model only

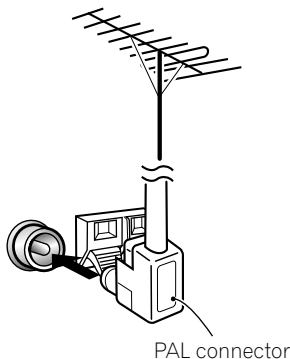

### All other models

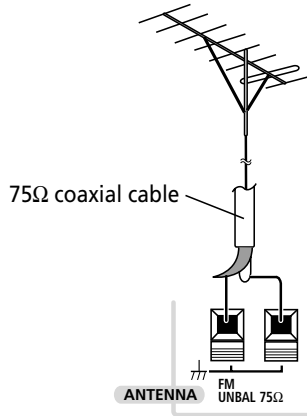

### Connecting auxiliary components

This system has both stereo analog inputs and outputs, as well as an optical digital input. Use these to connect external components, such as your TV, VCR, MD or CD-R recorder.

- **Connect the TV (IN) jacks on the rear panel to the audio outs of your TV (or VCR).**

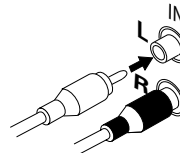

This will enable you to hear the TV (or VCR) sound through this system. Connect using RCA pin-plug stereo cables. See also *Reducing the TV and line signal levels* on page 48.

- Connect the **LINE 1 (IN)** jacks on the rear panel to an auxiliary playback component.

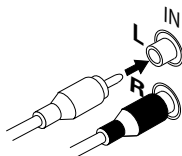

These include components such as a VCR or cassette deck. Connect using RCA pin-plug stereo cables. See also *Reducing the TV and line signal levels* on page 48.

- Connect the **LINE 1 (OUT)** jacks on the rear panel to a recording component.

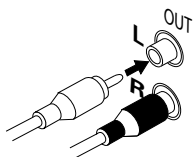

These include components such as a cassette deck, VCR, MD or another recorder with analog inputs. Connect using RCA pin-plug stereo cables.

- Connect the **LINE 2 (OPTICAL IN)** jack on the rear panel to the optical digital output of an auxiliary playback component.

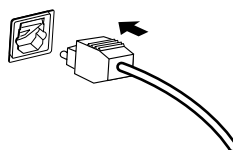

These include digital components such as an MD player, digital satellite, or a game system. Connect using an optical digital cable (not supplied).



#### Note

- The **LINE 2 (OPTICAL IN)** sound source can't be heard through the **LINE 1 (OUT)** jacks.

## Troubleshooting

Incorrect operations are often mistaken for trouble and malfunctions. If you think that there is something wrong with this component, check the points below. Sometimes the trouble may lie in another component. Investigate the other components and electrical appliances being used. If the trouble cannot be rectified even after exercising the checks listed below, ask your nearest Pioneer authorized service center or your dealer to carry out repair work.



**Note**

- If the unit does not operate normally due to external effects such as static electricity disconnect the power plug from the outlet and insert again to return to normal operating conditions.

## General

Problem	Remedy
The power does not turn on.	<ul style="list-style-type: none"> <li>• Connect the power plug to the wall outlet.</li> <li>• Disconnect the power plug from the outlet, and insert again.</li> <li>• Make sure there are no loose strands of speaker wire touching the rear panel. This could cause the unit to shut off automatically.</li> </ul>
No sound is output when a function is selected.	<ul style="list-style-type: none"> <li>• If you're using the line input, make sure the component is connected correctly (refer to the Setup Guide).</li> <li>• Press <b>MUTE</b> on the remote control to turn muting off.</li> <li>• Adjust the <b>MASTER VOLUME</b>.</li> </ul>
No image is output when watching discs.	<ul style="list-style-type: none"> <li>• Make sure the TV is connected correctly (refer to the Setup Guide).</li> </ul>
No sound from surround or center speakers.	<ul style="list-style-type: none"> <li>• Refer to <i>Setting the relative volume level of each channel</i> on page 41 to check the speaker levels.</li> <li>• Check that you haven't selected the <b>STEREO</b> sound mode (see <i>Listening to multi-channel playback</i> on page 44).</li> <li>• Connect the speakers properly (refer to the Setup Guide).</li> </ul>
Can't operate the remote control.	<ul style="list-style-type: none"> <li>• Replace the batteries (refer to the Setup Guide).</li> <li>• Operate within 23 feet ( 7 m), 30° of the remote sensor on the front panel (refer to the Setup Guide).</li> <li>• Remove any obstacles or operate from another position.</li> <li>• Avoid exposing the remote sensor on the front panel to direct light.</li> </ul>
Timer indicator is blinking and the unit will not switch on.	<ul style="list-style-type: none"> <li>• Unplug the unit for one minute then plug it back in and switch the unit on.</li> <li>• Make sure the fan at the rear of the unit is not being blocked.</li> <li>• Check that the speakers are connected correctly.</li> <li>• Make sure the voltage of the mains power source is correct for the model.</li> <li>• If the problem persists, take it to your nearest Pioneer authorized service center or your dealer for servicing.</li> </ul>

## DVD/CD/Video CD player

Problem	Remedy
The disc is ejected automatically after loading.	<ul style="list-style-type: none"> <li>• Clean the disc.</li> <li>• Align the disc properly in the disc guide.</li> <li>• If the region number on a DVD-video disc does not match the number on the player, the disc cannot be used (page 8).</li> <li>• Allow time for any condensation inside the player to evaporate. Avoid using the player near an air-conditioning unit.</li> </ul>
Playback is not possible.	<ul style="list-style-type: none"> <li>• If the disc is loaded upside down, reload the disc with the label side face up.</li> </ul>
Picture playback stops and the operation buttons cannot be used.	<ul style="list-style-type: none"> <li>• Press <b>■</b>, then start playback again (▶).</li> <li>• Switch the power off once, then on again using the front panel <b>STANDBY/ON</b> button.</li> </ul>
Settings are canceled.	<ul style="list-style-type: none"> <li>• When the power is cut due to power failure or by unplugging the power cord, settings will be canceled.</li> </ul>
No picture/No color.	<ul style="list-style-type: none"> <li>• Check that connections are correct and that plugs are inserted fully.</li> <li>• Check the instruction manual of the TV/monitor to make sure the TV/monitor settings are incorrect.</li> </ul>
Screen is stretched or aspect does not change.	<ul style="list-style-type: none"> <li>• The TV Screen setting is incorrect. Set the TV Screen option to match the TV/monitor you're using (page 51).</li> </ul>
When recorded on a VCR or passed through an AV selector, there is disturbance in the playback picture.	<ul style="list-style-type: none"> <li>• Due to the player's copy protection circuits, connection of this device through a VCR or an AV selector may prevent recording or cause picture problems. This is not a malfunction.</li> </ul>
Picture disturbance during playback or dark.	<ul style="list-style-type: none"> <li>• This player is compatible with Macro-Vision System copy guard. Some discs include a copy prevention signal, and when this type of disc is played back, stripes etc., may appear on some sections of the picture depending on the TV. This is not a malfunction.</li> <li>• Discs respond differently to particular player functions. This may result in the screen becoming black for a brief instant or shaking slightly when the function is executed. These problems are largely due to differences between discs and disc content and are not malfunctions of this player.</li> </ul>
The 96kHz display doesn't light when playing a 96kHz source.	<ul style="list-style-type: none"> <li>• If the 96kHz source is copy-protected the 96kHz display will not light.</li> </ul>
Noticeable difference in DVD and CD volume.	<ul style="list-style-type: none"> <li>• DVDs and CDs use different recording methods. This is not a malfunction.</li> </ul>



## Tuner

Problem	Remedy
Considerable noise in radio broadcasts.	<ul style="list-style-type: none"> <li>• Tune into the correct frequency.</li> <li>• Connect the antenna (refer to the Setup Guide).</li> <li>• Fully extend the FM wire antenna, position for best reception, and secure to a wall.</li> <li>• Connect an outdoor FM antenna (page 61).</li> <li>• Adjust the direction and position for best reception.</li> <li>• Connect an additional internal or external AM antenna (refer to the Setup Guide, page 61).</li> <li>• Turn off any other equipment that may be causing the noise or move it away from the unit.</li> <li>• The tuning interval is incorrect for your country or region. Try switching the tuning interval (frequency step) (page 57).</li> </ul>
Auto tuning does not pick up some stations.	<ul style="list-style-type: none"> <li>• The radio signal is weak. Auto tuning will only detect radio stations with a good signal. For more sensitive tuning, connect an outdoor antenna.</li> </ul>
Sound is mono only.	<ul style="list-style-type: none"> <li>• Check that the tuner is not set to FM mono (page 35).</li> </ul>

## Error Messages

Message	Description
<b>CHILD LOCK</b>	<ul style="list-style-type: none"> <li>• This message appears when the front panel buttons are pressed when the child lock feature is active. See Child Lock on page 58 for more on switching on/off the child lock.</li> </ul>
<b>CAN'T USE</b>	<ul style="list-style-type: none"> <li>• This message appears when it is not possible to output the test tone. Make sure the system is not muted, the headphones are not plugged in, and neither the <b>AUTO</b> or <b>STEREO</b> Surround mode is selected to output the test tone. See also <i>Setting the relative volume level of each channel</i> on page 41.</li> <li>• This message appears when you try to use the bass mode when the headphones are connected.</li> </ul>
<b>96K STEREO</b> or <b>96KHZ STEREO</b> (OSD only)	<ul style="list-style-type: none"> <li>• This message appears when the source sampling rate is 96kHz and you try to choose a Surround/Advanced Surround listening mode or try to adjust the bass or treble.</li> </ul>

## Screen sizes and disc formats

DVD-Video discs come in several different screen aspects, ranging from TV programs, which are generally 4:3, to CinemaScope widescreen movies, with an aspect ratio of up to about 7:3.

Televisions also come in different aspect ratios; 'standard' 4:3 and widescreen 16:9.

### Widescreen TV users

If you have a widescreen TV, the **TV Screen** setting (page 51) of this player should be set to **16:9 (Wide)**.

When you watch discs recorded in 4:3 format, you can use the TV controls to select how the picture is presented. Your TV may offer various zoom and stretch options; see the instructions that came with your TV for details.

Please note that some movie aspect ratios are wider than 16:9, so even though you have a widescreen TV, these discs will still play in a 'letterbox' style with black bars at the top and bottom of the screen.

### Standard TV users

If you have a standard TV, the TV Screen setting (page 52) of this player should be set to **4:3 (Letter Box)** or **4:3 (Pan&Scan)**, depending on which you prefer.

Set to **4:3 (Letter Box)**, widescreen discs are shown with black bars top and bottom.



Set to **4:3 (Pan&Scan)**, widescreen discs are shown with the left and right sides cropped. Although the picture looks larger, you don't actually see the whole picture.



Please note that many widescreen discs override the player's settings so that the disc is shown in letterbox format regardless of the setting.



#### Tip

- Using the **16:9 (Wide)** setting with a standard 4:3 TV, or either of the **4:3** settings with a widescreen TV, will result in a distorted picture.

## Language code list

Language (Language code letter), **Language code**

Japanese (ja), <b>1001</b>	Estonian (et), <b>0520</b>	Lingala (ln), <b>1214</b>	Slovak (sk), <b>1911</b>
English (en), <b>0514</b>	Basque (eu), <b>0521</b>	Laothian (lo), <b>1215</b>	Slovenian (sl), <b>1912</b>
French (fr), <b>0618</b>	Persian (fa), <b>0601</b>	Lithuanian (lt), <b>1220</b>	Samoa (sm), <b>1913</b>
German (de), <b>0405</b>	Finnish (fi), <b>0609</b>	Latvian (lv), <b>1222</b>	Shona (sn), <b>1914</b>
Italian (it), <b>0920</b>	Fiji (fj), <b>0610</b>	Malagasy (mg), <b>1307</b>	Somali (so), <b>1915</b>
Spanish (es), <b>0519</b>	Faroese (fo), <b>0615</b>	Maori (mi), <b>1309</b>	Albanian (sq), <b>1917</b>
Dutch (nl), <b>1412</b>	Frisian (fy), <b>0625</b>	Macedonian (mk), <b>1311</b>	Serbian (sr), <b>1918</b>
Russian (ru), <b>1821</b>	Irish (ga), <b>0701</b>	Malayalam (ml), <b>1312</b>	Siswati (ss), <b>1919</b>
Chinese (zh), <b>2608</b>	Scots-Gaelic (gd), <b>0704</b>	Mongolian (mn), <b>1314</b>	Sesotho (st), <b>1920</b>
Korean (ko), <b>1115</b>	Galician (gl), <b>0712</b>	Moldavian (mo), <b>1315</b>	Sundanese (su), <b>1921</b>
Greek (el), <b>0512</b>	Guarani (gn), <b>0714</b>	Marathi (mr), <b>1318</b>	Swedish (sv), <b>1922</b>
Afar (aa), <b>0101</b>	Gujarati (gu), <b>0721</b>	Malay (ms), <b>1319</b>	Swahili (sw), <b>1923</b>
Abkhazian (ab), <b>0102</b>	Hausa (ha), <b>0801</b>	Maltese (mt), <b>1320</b>	Tamil (ta), <b>2001</b>
Afrikaans (af), <b>0106</b>	Hindi (hi), <b>0809</b>	Burmese (my), <b>1325</b>	Telugu (te), <b>2005</b>
Amharic (am), <b>0113</b>	Croatian (hr), <b>0818</b>	Nauru (na), <b>1401</b>	Tajik (tg), <b>2007</b>
Arabic (ar), <b>0118</b>	Hungarian (hu), <b>0821</b>	Nepali (ne), <b>1405</b>	Thai (th), <b>2008</b>
Assamese (as), <b>0119</b>	Armenian (hy), <b>0825</b>	Norwegian (no), <b>1415</b>	Tigrinya (ti), <b>2009</b>
Aymara (ay), <b>0125</b>	Interlingua (ia), <b>0901</b>	Occitan (oc), <b>1503</b>	Turkmen (tk), <b>2011</b>
Azerbaijani (az), <b>0126</b>	Interlingue (ie), <b>0905</b>	Oromo (om), <b>1513</b>	Tagalog (tl), <b>2012</b>
Bashkir (ba), <b>0201</b>	Inupiak (ik), <b>0911</b>	Oriya (or), <b>1518</b>	Setswana (tn), <b>2014</b>
Byelorussian (be), <b>0205</b>	Indonesian (in), <b>0914</b>	Panjabi (pa), <b>1601</b>	Tonga (to), <b>2015</b>
Bulgarian (bg), <b>0207</b>	Icelandic (is), <b>0919</b>	Polish (pl), <b>1612</b>	Turkish (tr), <b>2018</b>
Bihari (bh), <b>0208</b>	Hebrew (iw), <b>0923</b>	Pashto, Pushto (ps), <b>1619</b>	Tsonga (ts), <b>2019</b>
Bislama (bi), <b>0209</b>	Yiddish (ji), <b>1009</b>	Portuguese (pt), <b>1620</b>	Tatar (tt), <b>2020</b>
Bengali (bn), <b>0214</b>	Javanese (jw), <b>1023</b>	Quechua (qu), <b>1721</b>	Twi (tw), <b>2023</b>
Tibetan (bo), <b>0215</b>	Georgian (ka), <b>1101</b>	Rhaeto-Romance (rm), <b>1813</b>	Ukrainian (uk), <b>2111</b>
Breton (br), <b>0218</b>	Kazakh (kk), <b>1111</b>	Kirundi (rn), <b>1814</b>	Urdu (ur), <b>2118</b>
Catalan (ca), <b>0301</b>	Greenlandic (kl), <b>1112</b>	Romanian (ro), <b>1815</b>	Tonga (uz), <b>2126</b>
Corsican (co), <b>0315</b>	Cambodian (km), <b>1113</b>	Kinyarwanda (rw), <b>1823</b>	Vietnamese (vi), <b>2209</b>
Czech (cs), <b>0319</b>	Kannada (kn), <b>1114</b>	Sanskrit (sa), <b>1901</b>	Volapük (vo), <b>2215</b>
Welsh (cy), <b>0325</b>	Kashmiri (ks), <b>1119</b>	Sindhi (sd), <b>1904</b>	Wolof (wo), <b>2315</b>
Danish (da), <b>0401</b>	Kurdish (ku), <b>1121</b>	Sangho (sg), <b>1907</b>	Xhosa (xh), <b>2408</b>
Bhutani (dz), <b>0426</b>	Kirghiz (ky), <b>1125</b>	Serbo-Croatian (sh), <b>1908</b>	Yoruba (yo), <b>2515</b>
Esperanto (eo), <b>0515</b>	Latin (la), <b>1201</b>	Sinhalese (si), <b>1909</b>	Zulu (zu), <b>2621</b>

## Country code list

Country, **Country code**, **Country code letter**

Argentina, <b>0118</b> , <b>ar</b>	Hong Kong, <b>0811</b> , <b>hk</b>	Philippines, <b>1608</b> , <b>ph</b>
Australia, <b>0121</b> , <b>au</b>	India, <b>0914</b> , <b>in</b>	Portugal, <b>1620</b> , <b>pt</b>
Austria, <b>0120</b> , <b>at</b>	Indonesia, <b>0904</b> , <b>id</b>	Russian Federation, <b>1821</b> , <b>ru</b>
Belgium, <b>0205</b> , <b>be</b>	Italy, <b>0920</b> , <b>it</b>	Singapore, <b>1907</b> , <b>sg</b>
Brazil, <b>0218</b> , <b>br</b>	Japan, <b>1016</b> , <b>jp</b>	Spain, <b>0519</b> , <b>es</b>
Canada, <b>0301</b> , <b>ca</b>	Korea, Republic of, <b>1118</b> , <b>kr</b>	Switzerland, <b>0308</b> , <b>ch</b>
Chile, <b>0312</b> , <b>cl</b>	Malaysia, <b>1325</b> , <b>my</b>	Sweden, <b>1905</b> , <b>se</b>
China, <b>0314</b> , <b>cn</b>	Mexico, <b>1324</b> , <b>mx</b>	Taiwan, <b>2023</b> , <b>tw</b>
Denmark, <b>0411</b> , <b>dk</b>	Netherlands, <b>1412</b> , <b>nl</b>	Thailand, <b>2008</b> , <b>th</b>
Finland, <b>0609</b> , <b>fi</b>	New Zealand, <b>1426</b> , <b>nz</b>	United Kingdom, <b>0702</b> , <b>gb</b>
France, <b>0618</b> , <b>fr</b>	Norway, <b>1415</b> , <b>no</b>	United States of America, <b>2119</b> , <b>us</b>
Germany, <b>0405</b> , <b>de</b>	Pakistan, <b>1611</b> , <b>pk</b>	

**Preset Code List**

<b>Manufacturer</b>	<b>Corde(s)</b>
ACURA	644
ADMIRAL	631
AIWA	660
AKAI	632, 635, 642
AKURA	641
ALBA	607, 639, 641, 644
AMSTRAD	642, 644, 647
ANITECH	644
ASA	645
ASUKA	641
AUDIOGONIC	607, 636
BASIC LINE	641, 644
BAUR	631, 607, 642
BEKO	638
BEON	607
BLAUPUNKT	631
BLUE SKY	641
BLUE STAR	618
BPL	618
BRANDT	636
BTC	641
BUSH	607, 641, 642, 644, 647, 656
CASCADE	644
CATHAY	607
CENTURION	607
CGB	642
CIMLINE	644
CLARIVOX	607
CLATRONIC	638
CONDOR	638
CONTEC	644
CROSLLEY	632
CROWN	638, 644
CRYSTAL	642
CYBERTRON	641
DAEWOO	607, 644, 656
DAINICHI	641
DANSAI	607
DAYTON	644
DECCA	607, 648
DIXI	607, 644
DUMONT	653
ELIN	607
ELITE	641
ELTA	644
EMERSON	642
ERRES	607
FERGUSON	607, 636, 651
FINLANDIA	635, 643, 655
FINLUX	632, 607, 645, 648, 653, 654, 655
FIRSTLINE	640, 644
FISHER	632, 635, 638, 645

<b>Manufacturer</b>	<b>Corde(s)</b>
FORMENTI	632, 607, 642
FRONTECH	631, 642, 646
FRONTECH	632
/PROTECH	
FUJITSU	648, 629
FUNAI	640, 646, 658
GBC	632, 642
GE	601, 608, 607, 610, 617, 602, 628, 618
GEC	607, 634, 648
GELOSO	632, 644
GENEXXA	631, 641
GOLDSTAR	610, 623, 621, 602, 607, 650
GOODMANS	607, 639, 647, 648, 656
GORENJE	638
GPM	641
GRAETZ	631, 642
GRANADA	607, 635, 642, 643, 648
GRADIENTE	630, 657
GRANDIN	618
GRUNDIG	631, 653
HANSEATIC	607, 642
HCM	618, 644
HINARI	607, 641, 644
HISAWA	618
HITACHI	631, 633, 634, 636, 642, 643, 654, 606, 610, 624, 625, 618
HUANYU	656
HYPSON	607, 618, 646
ICE	646, 647
IMPERIAL	638, 642
INDIANA	607
INGELEN	631
INTERFUNK	631, 632, 607, 642
INTERVISION	646, 649
ISUKAI	641
ITC	642
ITT	631, 632, 642
JEC	605
JVC	613, 623
KAISUI	618, 641, 644
KAPSCH	631
KENDO	642
KENNEDY	632, 642
KORPEL	607
KOYODA	644
LEYCO	607, 640, 646, 648
LIESENK&TTER	607
LOEWE	607
LUXOR	632, 642, 643
M-ELECTRONIC	631, 644, 645, 654, 655, 656, 607, 636, 651
MAGNADYNE	632, 649
MAGNAFON	649

<b>Manufacturer</b>	<b>Corde(s)</b>
MAGNAVOX	607, 610, 603, 612, 629
MANESTH	639, 646
MARANTZ	607
MARK	607
MATSUI	607, 639, 640, 642, 644, 647, 648
MCMICHAEL	634
MEDIATOR	607
MEMOREX	644
METZ	631
MINERVA	631, 653
mitsubishi	609, 610, 602, 621, 631
MULTITECH	644, 649
NEC	659
NECKERMANN	631, 607
NEI	607, 642
NIKKAI	605, 607, 641, 646, 648
NOBLIKO	649
NOKIA	632, 642, 652
NORDMENDE	632, 636, 651, 652
OCEANIC	631, 632, 642
ORION	632, 607, 639, 640
OSAKI	641, 646, 648
OSO	641
OSUME	648
OTTO VERSAND	631, 632, 607, 642
PALLADIUM	638
PANAMA	646
PANASONIC	631, 607, 608, 642, 622
PATHO CINEMA	642
PAUSA	644
PHILCO	632, 642
PHILIPS	631, 607, 634, 656
PHOENIX	632
PHONOLA	607
PROFEX	642, 644
PROTECH	607, 642, 644, 646, 649
QUELLE	631, 632, 607, 642, 645, 653
R-LINE	607
RADIOLA	607
RADIO SHACK	610, 623, 621, 602
RBM	653
RCA	601, 610, 615, 616, 617, 618, 661, 662, 609
REDIFFUSION	632, 642
REX	631, 646
ROADSTAR	641, 644, 646
SABA	631, 636, 642, 651
SAISHO	639, 644, 646
SALORA	631, 632, 642, 643
SAMBERS	649
SAMSUNG	607, 638, 644, 646
SANYO	635, 645, 648, 621, 614
SBR	607, 634
SCHAUB LORENZ	642

<b>Manufacturer</b>	<b>Corde(s)</b>
SCHNEIDER	607, 641, 647
SEG	642, 646
SEI	632, 640, 649
SELECO	631, 642
SHARP	602, 619, 627
SIAREM	632, 649
SIEMENS	631
SINUDYNE	632, 639, 640, 649
SKANTIC	643
SOLAVOX	631
SONOKO	607, 644
SONOLOR	631, 635
SONTEC	607
SONY	604
SOUNDWAVE	607
STANDARD	641, 644
STERN	631
SUSUMU	641
SYSLINE	607
TANDY	631, 641, 648
TASHIKO	634
TATUNG	607, 648
TEC	642
TELEAVIA	636
TELEFUNKEN	636, 637, 652
TELETECH	644
TENSAI	640, 641
THOMSON	636, 651, 652, 663
THORN	631, 607, 642, 645, 648
TOMASHI	618
TOSHIBA	605, 602, 626, 621, 653
TOWADA	642
ULTRAVOX	632, 642, 649
UNIVERSUM	631, 607, 638, 642, 645, 646, 654, 655
VESTEL	607
VICTOR	613
VOXSON	631
WALTHAM	643
WATSON	607
WATT RADIO	632, 642, 649
WHITE	
WESTINGHOUSE	607
YOKO	607, 642, 646
ZENITH	603, 620
PIONEER	600, 631, 632, 607, 636, 642, 651



**Note**

- Please note that there are cases where the codes for the manufacturer in the list will not work for the model that you are using.

## Glossary

### Analog audio

An electrical signal that directly represents sound. Compare this to digital audio which can be an electrical signal, but is an indirect representation of sound. See also *Digital audio*.

### Aspect ratio

The width of a TV screen relative to its height. Conventional TVs are 4:3 (in other words, the screen is almost square); widescreen models are 16:9 (the screen is almost twice as wide as it is high).

### Digital audio

An indirect representation of sound by numbers. During recording, the sound is measured at discrete intervals (44,100 times a second for CD audio) by an analog-to-digital converter, generating a stream of numbers. On playback, a digital-to-analog converter generates an analog signal based on these numbers. See also *Sampling frequency* and *Analog audio*.

### Dolby Digital



Using a maximum of 5.1 channels of audio, this high quality surround system is used in many of the finer movie theaters around the world.

### DTS



DTS stands for Digital Theater System. DTS is a surround system different from Dolby Digital that has become a popular surround sound format for movies.

### Dynamic range

The difference between the quietest and loudest sounds possible in an audio signal (without distorting or getting lost in noise). Dolby Digital and DTS soundtracks are capable of a very wide dynamic range, delivering dramatic cinema-like effects.

### File extension

A tag added to the end of a filename to indicate the type of file. For example, ".mp3" indicates an MP3 file.

### MP3

MP3 (MPEG1 audio layer 3) is a compressed audio file format. Files are recognized by their file extension ".mp3" or ".MP3".

### MPEG audio

An audio format used on Video CDs and some DVD discs. This unit can convert MPEG audio to PCM format for wider compatibility with digital recorders and AV amplifiers. See also *PCM*.

### MPEG video

The video format used for Video CDs and DVDs. Video CD uses the older MPEG-1 standard, while DVD uses the newer and much better quality MPEG-2 standard.

### PCM (Pulse Code Modulation)

The most common system of encoding digital audio, found on CDs and DAT. Excellent quality, but requires a lot of data compared to formats such as Dolby Digital and MPEG audio. See also *Digital audio*.

### PBC (PlayBack Control) (Video CD only)

A system of navigating a Video CD through on-screen menus recorded onto the disc. Especially good for discs that you would normally not watch from beginning to end all at once—karaoke discs, for example.

### Regions (DVD-Video only)

These associate discs and players with particular areas of the world. This unit will only play discs that have compatible region codes. You can find the region code of your unit by looking on the rear panel. Some discs are compatible with more than one region (or all regions).

### Sampling frequency

The rate at which sound is measured to be turned into digital audio data. The higher the rate, the better the sound quality, but the more digital information is generated. Standard CD audio has a sampling frequency of 44.1kHz, which means 44,100 samples (measurements) per second. See also *Digital audio*.

*Manufactured under license from Dolby Laboratories. "Dolby", "Pro Logic", and double-D symbol are trademarks of Dolby Laboratories.*

*"DTS" and "DTS Digital Surround" are trademarks of Digital Theater Systems, Inc. Manufactured under license from Digital Theater Systems, Inc.*

## Specifications

### Amplifier section

Continuous Power Output (RMS):

Front, center, surround ..... 75 W per channel  
(1 kHz, 10 % T.H.D., 6  $\Omega$ )

Subwoofer ... 75 W (100 Hz, 10 % T.H.D., 6  $\Omega$ )

Continuous Power Output :

Front, center, surround ..... 62 W per channel  
(1 kHz, 1 % T.H.D., 6  $\Omega$ )

Subwoofer ..... 62 W (100 Hz, 1 % T.H.D., 6  $\Omega$ )

### Disc section

Digital audio characteristics ..... DVD fs: 96 kHz, 24-bit  
Type ..... DVD system, video CD system and compact disc digital audio system

Frequency response ..... 4 Hz to 44 kHz  
Wow and Flutter ..... Limit of measurement ( $\pm 0.001$  % W.PEAK) or less (EIAJ)

### FM tuner section

Frequency range ..... 87.5 – 108 MHz

Antenna ..... 75  $\Omega$ , unbalanced

### AM tuner section

Frequency range

With 9 kHz step ..... 531 kHz to 1,602 kHz

With 10 kHz step ..... 530 kHz to 1,700 kHz

(*not applicable to European model*)

Antenna ..... Loop antenna

### Miscellaneous

Power requirements

European model ..... AC 220–230 V, 50/60 Hz

U.S. model ..... AC 120 V, 60 Hz

Singapore model .... AC 220–230 V, 50/60 Hz

Hong Kong model ..... AC 220–230 V, 50 Hz

Taiwan model ..... AC 110-120 V, 60 Hz

Power consumption

European model ..... 195 W

U.S. model ..... 215 W

Singapore model ..... 195 W

Hong Kong model ..... 565 W

Taiwan model ..... 193 W

Power consumption in standby

European model ..... 0.39 W

U.S. model ..... 0.38 W

Singapore model ..... 0.39 W

Hong Kong model ..... 0.39 W

Taiwan model ..... 0.37 W

Dimensions ..... 360 (W) x 70 (H) x 393 (D) mm/  
14-3/16 (W) x 2-3/4 (H) x 15-1/2 (D) in.

Weight ..... 7.0 kg/15 lb 7 oz

### Accessories (DVD/CD receiver)

Remote control ..... 1

AA/R6P dry cell batteries ..... 2

Video cable (yellow plugs) ..... 1

AM loop antenna ..... 1

FM antenna ..... 1

Power cord ..... 1

Warranty Card

(European and U.S. models only) ..... 1

Operating instructions

Quick setup guide

### Speaker System

#### Front speakers

Enclosure ..... Closed-box bookshelf type  
(magnetically shielded)

System ..... 2-way system

Speakers

Woofers ..... 15 x 6 cm cone type

Tweeter ..... 5.2 cm cone type

Nominal impedance ..... 6  $\Omega$

Frequency range ..... 80 Hz to 20 kHz

Maximum Input Power ..... 75 W

Dimensions .. 220 (W) x 1,250 (H) x 220 (D) mm  
8-11/16 (W) x 49-1/4 (H) x 8-11/16 (D) in.

Weight ..... 6.6 kg/14 lb 9 oz

#### Center speaker

Enclosure ..... Closed-box bookshelf type  
(magnetically shielded)

System ..... 8.7 cm 1-way system

Speakers ..... 8.7 cm cone type

Nominal impedance ..... 6  $\Omega$

Frequency range ..... 100 Hz to 20 kHz

Maximum Input Power ..... 75 W

Dimensions ..... 200 (W) x 110 (H) x 76 (D) mm/  
7-7/8 (W) x 4-5/16 (H) x 3 (D) in.

Weight ..... 0.8 kg/1 lb 12 oz



## Additional information

### Surround speakers

Enclosure .....	Closed-box bookshelf type (magnetically shielded)
System .....	8.7 cm 1-way system
Speakers .....	8.7 cm cone type
Nominal impedance .....	6 $\Omega$
Frequency range .....	100 Hz to 20 kHz
Maximum Input Power .....	75 W
Dimensions .....	110 (W) x 155 (H) x 76 (D) mm/ 4-5/16 (W) x 6-1/8 (H) x 3 (D) in.
Weight .....	0.75 kg/1 lb 10 oz

### Subwoofer

Enclosure .....	Bass-reflex floor type (magnetically shielded)
System .....	16 cm 1-way system
Speaker .....	16 cm cone type
Nominal impedance .....	6 $\Omega$
Frequency range .....	30 Hz to 2.8 kHz
Maximum Input Power .....	75 W
Dimensions .....	130 (W) x 360 (H) x 360 (D) mm/ 5-1/8 (W) x 14-3/16 (H) x 14-3/16 (D) in.
Weight .....	4.0 kg/8 lb 13 oz

### Accessories (Speaker system)

Speaker cords .....	6
Non-slip pads .....	16
Stem .....	2
Base .....	2
Cap .....	2
Flathead screws .....	4
Captive washer screws .....	4
Ruler .....	1



#### Note

- Specifications and design subject to possible modification without notice, due to improvements.

This product includes FontAvenue® fonts licenced by NEC corporation. FontAvenue is a registered trademark of NEC Corporation.

### Power cord caution

Handle the power cord by the plug part. Do not pull out the plug by tugging the cord, and never touch the power cord when your hands are wet, as this could cause a short circuit or electric shock. Do not place the unit, a piece of furniture, or other object on the power cord or pinch the cord in any other way. Never make a knot in the cord or tie it with other cords. The power cords should be routed so that they are not likely to be stepped on. A damaged power cord can cause a fire or give you an electric shock. Check the power cord once in a while. If you find it damaged, ask your nearest Pioneer authorized service center or your dealer for a replacement.

This product is for general household purposes. Any failure due to use for other than household purposes (such as long-term use for business purposes in a restaurant or use in a car or ship) and which requires repair will be charged for even during the warranty period. **K041\_En**

Please read through these operating instructions so you will know how to operate your model properly. After you have finished reading the instructions, put them away in a safe place for future reference.

- This player is not suitable for commercial use.

This product incorporates copyright protection technology that is protected by method claims of certain U.S. patents and other intellectual property rights owned by Macrovision Corporation and other rights owners. Use of this copyright protection technology must be authorized by Macrovision Corporation, and is intended for home and other limited viewing uses only unless otherwise authorized by Macrovision Corporation. Reverse engineering or disassembly is prohibited.





## AFTER-SALES SERVICE FOR PIONEER PRODUCTS

Please contact the dealer or distributor from where you purchased the product for its after-sales service (including warranty conditions) or any other information. In case the necessary information is not available, please contact the Pioneer's subsidiaries (regional service headquarters) listed below:

PLEASE DO NOT SHIP YOUR PRODUCT TO THE COMPANIES at the addresses listed below for repair without advance contact, for these companies are not repair locations.

### AMERICA

PIONEER ELECTRONICS (USA) INC.  
CUSTOMER SUPPORT DIVISION  
P.O. BOX 1760, LONG BEACH, CA 90801-1760, U.S.A.  
CUSTOMER SERVICE HOTLINE : (800) 421-1404

### EUROPE

PIONEER EUROPE NV  
EUROPEAN SERVICE DIVISION  
HAVEN 1087, KEETBERGLAAN 1, B-9120 MELSELE, BELGIUM

### ASEAN

PIONEER ELECTRONICS ASIACENTRE PTE. LTD.  
SERVICE DEPARTMENT  
253, ALEXANDRA ROAD #04-01 SINGAPORE 159936

### JAPAN AND OTHERS

PIONEER CORPORATION (HEAD OFFICE)  
CUSTOMER SUPPORT CENTER  
4-1, MEGURO 1-CHOME, MEGURO-KU, TOKYO 153-8654 JAPAN

S016D\_en

Published by Pioneer Corporation.  
Copyright © 2002 Pioneer Corporation.  
All rights reserved.

---

## **PIONEER CORPORATION**

4-1, Meguro 1-Chome, Meguro-ku, Tokyo 153-8654, Japan

### **PIONEER ELECTRONICS (USA) INC.**

P.O. BOX 1540, Long Beach, California 90810-1540, U.S.A. TEL: (800) 421-1404

### **PIONEER ELECTRONICS OF CANADA, INC.**

300 Allstate Parkway, Markham, Ontario L3R 0P2, Canada TEL: (905) 479-4411

### **PIONEER EUROPE NV**

Haven 1087, Keetberglaan 1, B-9120 Melsele, Belgium TEL: 03/570.05.11

### **PIONEER ELECTRONICS ASIACENTRE PTE. LTD.**

253 Alexandra Road, #04-01, Singapore 159936 TEL: 656-472-1111

### **PIONEER ELECTRONICS AUSTRALIA PTY. LTD.**

178-184 Boundary Road, Braeside, Victoria 3195, Australia, TEL: (03) 9586-6300

### **PIONEER ELECTRONICS DE MEXICO S.A. DE C.V.**

San Lorenzo 1009 3er Piso Desp. 302 Col. Del Valle Mexico D.F. C.P. 03100 TEL: 55-5688-52-90

K002D